

Instant Pot®

DUO CRISP™ + AIR FRYER

Multi-Use Pressure Cooker and Air Fryer

6 & 8 Quart



User Manual

Important Safeguards
Product Specifications
Initial Setup
Product, Parts and Accessories
Smart Program Settings
Cleaning Before First Use
Overview of Pressure Control
Features
Initial Test Run (Water Test)
Cooking with the Duo Crisp
Recommended Cooking Times
Care and Cleaning
Troubleshooting
Warranty
Contact Information

Welcome to the world of Instant cooking.

Thank you for welcoming us into your kitchen.

Having families ourselves, we developed the Instant Pot® Duo Crisp™ + Air Fryer to allow busy families and professionals alike to cook healthy, delicious meals more easily and in less time.

We have partnered with chefs, authors and bloggers to compile a collection of recipes that we hope you enjoy!

Happy cooking,



Robert J. Wang
Founder and Chief Innovation Officer



Download the Instant Pot App

- Original Recipes
- New User Tips
- Getting Started Videos



Find helpful [how-to videos](#), [download the app](#), or visit our [recipe](#) site.

Table of Contents

IMPORTANT SAFEGUARDS	5
Special Cord Set Instructions	10
Product Specifications.....	10
Initial Setup	11
Product, Parts and Accessories	12
Control Panel	17
Smart Program Settings	19
Cancel and Standby Mode	19
Turn Sound On/Off.....	19
Adjust Temperature Scale: °F or °C.....	19
Set a Delay Start Timer	19
Automatically Keep Food Warm After Cooking	19
Reheat Food or Keep Warm for Long Periods.....	20
Adjust and Save Custom Temperatures	20
Reset Smart Programs to Factory Default Settings	20
Status Messages	21
Cleaning Before First Use	22
Overview of Pressure Control Features	24
Pressure Cooking Lid	24
Quick Release Button	25
Steam Release Valve	26
Anti-Block Shield	27
Sealing Ring.....	28
Float Valve.....	29
Condensation Collector.....	30
Introduction to Pressure Cooking	31

Table of Contents

Depressurizing the Cooker (Venting Methods)	33
Natural Release (NR)	33
Quick Release (QR).....	33
10-Minute NR	34
Initial Test Run (Water Test)	35
Smart Programs: Non Air Frying	36
Pressure Cook and Steam	36
Sauté	39
Slow Cook	41
Sous Vide	42
Sous Vide Cooking Guidelines	44
Smart Programs: Air Frying (Air Fryer Lid).....	46
Air Fry	46
Roast	48
Bake	49
Broil.....	50
Dehydrate	51
Smart Program Overview	52
Cooking Time Chart	53
Care and Cleaning	54
Troubleshooting.....	56
Warranty.....	60
Contact Information	62

IMPORTANT SAFEGUARDS

When using electrical appliances, basic safety precautions should always be followed:

1. READ THE *GETTING STARTED GUIDE* AND ALL INSTRUCTIONS, SAFEGUARDS, AND WARNINGS BEFORE OPERATING THE APPLIANCE. FAILURE TO FOLLOW THESE SAFEGUARDS AND INSTRUCTIONS MAY RESULT IN INJURY AND/OR PROPERTY DAMAGE.
2. Use only the Instant Pot Duo Crisp pressure cooking lid and Duo Crisp Air Fryer lid with the Instant Pot Duo Crisp cooker base. Using any other pressure cooker lids or air fryer lids may cause injury and/or damage.
3. To reduce the risk of pressure leakage, cook only in an authorized stainless steel Instant Pot inner pot. DO NOT use the appliance without the removable inner pot installed.
4. Always use an Instant Pot stainless steel inner pot when using the Air Fryer Lid. Do not use a ceramic coated inner pot.
5. **⚠ DANGER** When pressure cooking, **do not open the appliance until it has depressurized**, and all internal pressure has been released. If the float valve is still up and/or the lid is difficult to open, this indicates that the appliance is still pressurized—**do not force it open**. Any pressure in the appliance can be hazardous. Refer to [Depressurizing the Cooker \(Venting Methods\)](#) for information on releasing pressure. Opening the appliance while it is still pressurized may lead to sudden release of hot contents and may cause burns or other injuries.
6. Always operate the appliance on a stable, non-combustible, level surface.
7. Do not use the appliance for anything other than its intended use. Failure to follow this instruction may result in injury or property damage.
8. For household use only. Do not use outdoors. Not for commercial use.
9. **⚠ CAUTION** Do not place the appliance on or in close proximity to a hot gas or electric burner, or a heated oven. Heat from an external source will damage the appliance. Failure to follow these instructions may result in injury or property damage.
10. **⚠ CAUTION** Do not use the appliance near water or flame. Keep out of direct sunlight. Failure to follow these instructions may result in injury or property damage.
11. **⚠ CAUTION** Do not touch hot surfaces. Only use side handles for carrying or moving. Extreme caution must be used when moving the appliance containing hot liquids. Do not move the appliance when it is under pressure.



WARNING Read this manual carefully and completely, and retain for future reference. Failure to adhere to safety instructions may result in serious injury or damage.

IMPORTANT SAFEGUARDS

12. **⚠ CAUTION** The cooker base and air fryer lid contain electrical components. To avoid electrical shock, do not put liquid of any kind into cooker base or air fryer lid, and do not immerse power cord, plug, or the appliance in water or other liquid. Do not rinse the appliance under tap.
13. **⚠ CAUTION** Do not fill over **PC MAX – 2/3** as indicated on the inner pot. When cooking foods that expand during cooking such as rice or dried vegetables, do not fill the inner pot over – **1/2 line**. Overfilling may cause a risk of clogging the steam release pipe and developing excess pressure.
14. **⚠ WARNING** This appliance cooks under pressure. Make certain the appliance is properly closed before operating. Failure to do so may result in burns, injury and/or property damage.
15. When cooking meat with skin (e.g., sausage with casing), the skin can swell when heated. Do not pierce the skin while it is swollen; this could result in scalding injury.
16. **⚠ CAUTION** When pressure cooking food with a doughy or thick texture, or a high fat/oil content, contents may splatter when opening the lid. Please follow recipe instructions for pressure release method. Refer to [Depressurizing the Cooker \(Venting Methods\)](#).
17. **⚠ CAUTION** Before using the pressure cooking lid, check the steam release valve, steam release pipe, anti-block shield and float valve for clogging. Failure to do so may result in injury or property damage.
18. Do not use this appliance for deep frying or pressure frying with oil.
19. Do not lean over or place your hands or face over the steam release valve or float valve when the appliance is in operation or has residual pressure. Do not touch the metal portion of the lid when the appliance is in operation as this could result in injury.
20. Do not cover or obstruct the steam release valve and/or the float valve with cloth or any other objects. Covering or obstructing the steam release valve and/or float valve can create a safety issue and may cause injury.
21. Turn the appliance off if steam escapes from the steam release valve and/or float valve in a steady stream for longer than 3 minutes. There may be residual pressure in the appliance. Allow the appliance to depressurize naturally or release all excess pressure before opening. Refer to [Depressurizing the Cooker \(Venting Methods\)](#) for information on releasing pressure.



Read this manual carefully and completely, and retain for future reference. Failure to adhere to safety instructions may result in serious injury or damage.

IMPORTANT SAFEGUARDS

22. Turn the appliance off if steam escapes from the sides of the lid and ensure sealing ring is properly installed. Refer to [Pressure Control Features–Sealing Ring](#) for information on checking the sealing ring.
23. To disconnect, press **Cancel**, then remove plug from power source.
24. Unplug from the outlet when not in use, as well as before adding or removing parts or accessories, and before cleaning. To unplug, grasp the plug and pull from the outlet. Never pull from the power cord.
25. Regularly inspect the appliance and power cord. Do not operate the appliance if the power cord or plug is damaged, or after the appliance malfunctions or is dropped or damaged in any manner. For assistance, contact Customer Care at support@instantpot.com or **1-800-828-7280**.
26. **⚠ CAUTION** Do not let the power cord hang over edges of tables or counters, or touch hot surfaces or open flame, including the stovetop.
27. **⚠ CAUTION** Spilled food can cause serious burns. A short power-supply cord is provided to reduce the hazards resulting from grabbing, entanglement and tripping.
 - Keep the appliance and cord away from children.
 - Never drape the power cord over edges of tables or counters.
 - Never use below-counter power outlets, and never use with an extension cord.
28. Intended for countertop use only. Keep the appliance on a stable, heat-resistant platform. Do not place on anything that may block the vents on the bottom of the cooker base or on the air fryer lid. Leave at least 5" / 13 cm of space around the air fryer lid when in use. Do not place the appliance on a hot stove. Do not operate the appliance on or near combustible materials such as tablecloths and curtains.
29. **⚠ CAUTION** Do not cover the air vents while the air fryer lid is in operation. Doing so will prevent even cooking and may cause damage to the appliance.
30. **⚠ CAUTION** Do not use any accessories or attachments not authorized by Instant Brands Inc. The use of attachments not recommended by the manufacturer may cause a risk of injury, fire or electric shock.
31. **⚠ CAUTION** Before inserting the inner pot into the appliance, wipe the outer surface of the inner pot as well as the heating element, located at the bottom of the interior of the cooker base, with a clean dry cloth. Ensure they are dry and free of debris. Refer to [Care and Cleaning](#). Failure to do so may result in injury or property damage.



WARNING Read this manual carefully and completely, and retain for future reference. Failure to adhere to safety instructions may result in serious injury or damage.

IMPORTANT SAFEGUARDS

32. Do not attempt to repair, replace or modify components of the appliance, as this may cause electric shock, fire or injury, and will void the warranty.
33. Do not tamper with any of the safety mechanisms as this may result in injury or property damage.
34. Avoid contact with moving parts as this may result in injury.
35. Do not use the appliance in electrical systems other than 120 V ~ 60 Hz for North America. Do not use with power converters or adapters.
36. This appliance is NOT to be used by children or by persons with reduced physical, sensory or mental capabilities. Close supervision is necessary when any appliance is used near children and these individuals. Children should not play with this appliance.
37. To prevent personal injury and damage to the appliance, only replace the sealing ring with an authorized Instant Pot sealing ring. Visit our store for purchasing details.
38. The use of accessory attachments not recommended by the appliance manufacturer may cause injuries.
39. Proper maintenance is recommended after each use. Refer to [Care and Cleaning](#). Let the appliance cool to room temperature before cleaning or storage.
40. When using the air fryer lid, do not overfill the air fryer basket. Overfilling may cause food to contact the heating element, which may result in fire and/or personal injury.
41. Never connect this appliance to an external timer switch or separate remote-control system.
42. **⚠ CAUTION** DO NOT touch accessories during or immediately after cooking. To avoid personal injury,
 - Always use oven mitts when removing accessories, and to handle the inner pot.
 - Always place hot accessories on a heat-resistant surface or cooking plate.
 - Only place the air fryer lid on the protective pad provided; do not place on countertop.
 - Use extreme caution when disposing of hot grease.Failure to do so may result in serious injury or property damage.
43. While cooking, the internal temperature of the appliance reaches several hundred degrees. To avoid personal injury, never place unprotected hands inside the appliance until it has cooled to room temperature.



Read this manual carefully and completely, and retain for future reference. Failure to adhere to safety instructions may result in serious injury or damage.

IMPORTANT SAFEGUARDS

44. **⚠ CAUTION** When the air fryer lid is in operation, hot air is released through the air vents. Keep your hands and face at a safe distance from the air vents and take extreme caution when removing hot accessories from the appliance. Failure to do so may result in injury or property damage.
45. Should the unit emit black smoke when using the air fryer lid, press **Cancel** and unplug the appliance immediately. Wait for smoking to stop before removing the lid, then clean thoroughly. For further information refer to [Troubleshooting](#).
46. Do not leave the appliance unattended while in use.
47. **⚠ CAUTION** Extreme caution must be used when the inner pot contains hot food, hot oil or other hot liquids. Improper use, including moving the air fryer lid or cooker base, may result in personal injury. Do not move the appliance while it is in use.
48. Oversized foods and/or metal utensils must not be inserted into the inner pot or air fryer basket as they may cause risk of fire and/or personal injury.
49. Do not store any materials in the cooker base or inner pot when not in use.
50. Do not place any combustible materials in the cooker base or inner pot, such as paper, cardboard, plastic, Styrofoam or wood.
51. Do not use the included accessories in a microwave, toaster oven, convection or conventional oven, or on a ceramic cooktop, electric coil, gas range, or outdoor grill.
52. The removable inner pot can be extremely heavy when full of ingredients. Care should be taken when lifting the inner pot from the cooker base to avoid burn injury.
53. Use caution when removing the lid. Heat and steam escape as soon as the lid is removed. Never place your face, hands or exposed skin over the appliance opening where heat and steam escape when removing the lid.

SAVE THESE INSTRUCTIONS



Read this manual carefully and completely, and retain for future reference. Failure to adhere to safety instructions may result in serious injury or damage.

IMPORTANT SAFEGUARDS

WARNING

To avoid injury, read and understand instruction manual before using this machine.

WARNING

Electrical shock hazard. Use grounded outlet only. DO NOT remove ground. DO NOT use an adapter. DO NOT use an extension cord. Failure to follow instructions can cause electrical shock and/or death.

WARNING





THE FAILURE TO FOLLOW ANY OF THE IMPORTANT SAFEGUARDS AND THE IMPORTANT INSTRUCTIONS FOR SAFE USE IS A MISUSE OF YOUR APPLIANCE THAT CAN VOID YOUR WARRANTY AND CREATE THE RISK OF SERIOUS INJURY.

Special Cord Set Instructions

As per safety requirement, a short power supply cord is provided to reduce the hazards resulting from entanglement and tripping.

This appliance has a 3-prong grounding plug. To reduce the risk of electric shock, plug the power cord into a grounded (earthed) electrical outlet that is easily accessible.

Product Specifications

				
Model: DUO CRISP AF 6	1500 W	120 V~ 60 Hz	6 Quart / 5.7 Litres	19.62 lbs / 8.9 kg
Model: DUO CRISP AF 8	1500 W	120 V~ 60 Hz	8 Quart / 7.6 Litres	22.18 lbs / 10.06 kg

	DUO CRISP AF 6		DUO CRISP AF 8	
	With Pressure Cooker Lid:		With Pressure Cooker Lid:	
	in: 13.58 L x 13.58 W x 12.99 H		in: 14.76 L x 13.58 W x 14.17 H	
	cm: 34.5 L x 34.5 W x 33 H		cm: 37.5 L x 34.5 W x 36 H	
With Air Fryer Lid:		With Air Fryer Lid:		
in: 13.58 L x 13.58 W x 13.97 H		in: 14.76 L x 13.58 W x 15.28 H		
cm: 34.5 L x 34.5 W x 35.5 H		cm: 37.5 L x 34.5 W x 38.8 H		

WARNING

Read this manual carefully and completely, and retain for future reference. Failure to adhere to safety instructions may result in serious injury or damage.

Initial Setup

- Read all of the **Important Safeguards** in this User Manual before using the appliance. Failure to do so may result in property damage and/or personal injury.
- Use only the Instant Pot Duo Crisp pressure cooking lid and air fryer lid with the Instant Pot Duo Crisp cooker base. Using any other pressure cooker lids or air fryer lids may cause injury and/or damage.
- Remove all packaging material and accessories from within and around the appliance.
- Place the appliance on a stable, level surface, away from combustible material and external heat sources.
- Leave at least 5" / 13 cm of space around the appliance when using the air fryer lid.
- Do not remove the safety warning stickers from the lids, or the serial number or rating label from the cooker base.
- Follow **Care and Cleaning** instructions to wash the appliance before cooking.

CAUTION

Do not place the appliance on a stovetop.	Do not place anything on top of the appliance.	Do not block or cover the steam release valve located on the pressure cooking lid.	Do not block the air vents on the air fryer lid.
---	--	--	--

Product, Parts and Accessories

Duo Crisp + Air Fryer 6 & 8 Quart

Before using the Instant Pot Duo Crisp, verify that all parts are accounted for.

Pressure Cooking Lid

Use the following programs with the pressure cooking lid: Pressure Cook, Sauté, Slow Cook, Steam, Sous Vide, Delay Start and Keep Warm. These programs do not air fry.

Top

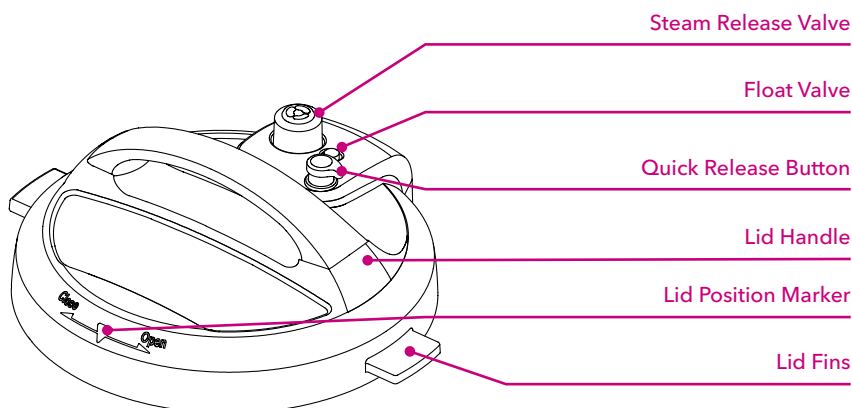

Interior

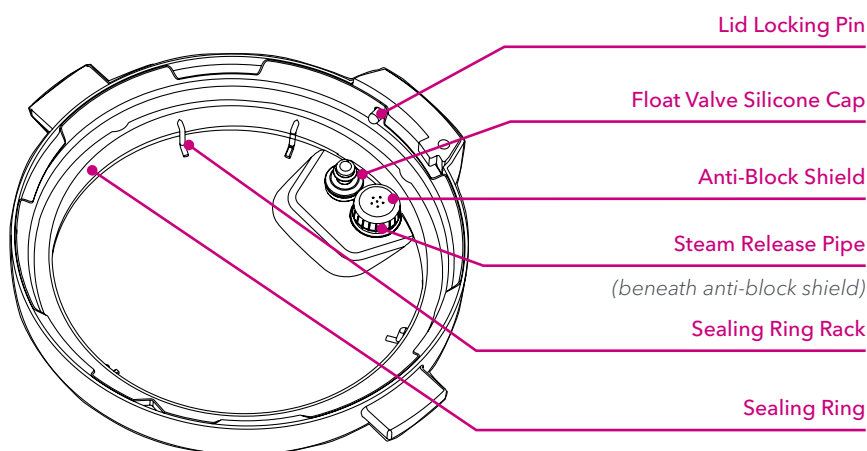

Illustrations are for reference only and may differ from the actual product.

Product, Parts and Accessories

Air Fryer Lid

Use the following Smart Programs with the air fryer lid: Air Fry, Roast, Bake, Broil and Dehydrate.

Front

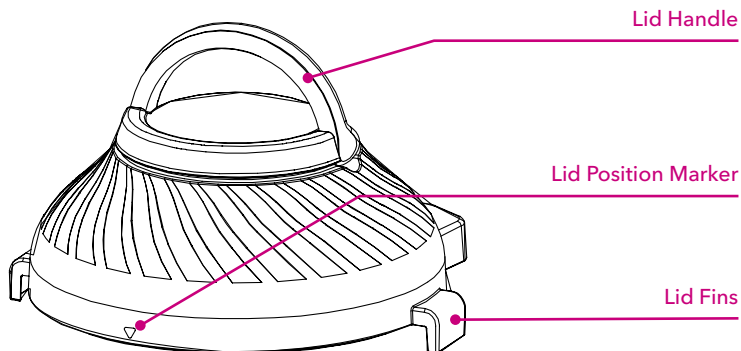

Back

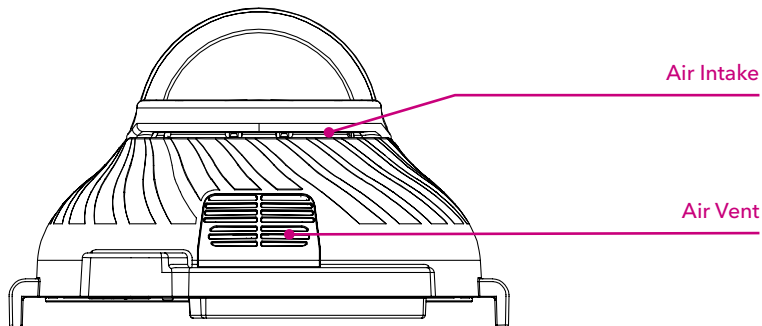

Interior

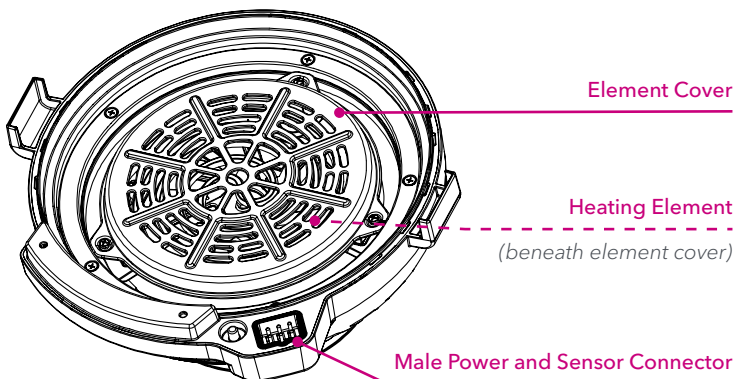

Illustrations are for reference only and may differ from the actual product.

Product, Parts and Accessories

Inner Pot

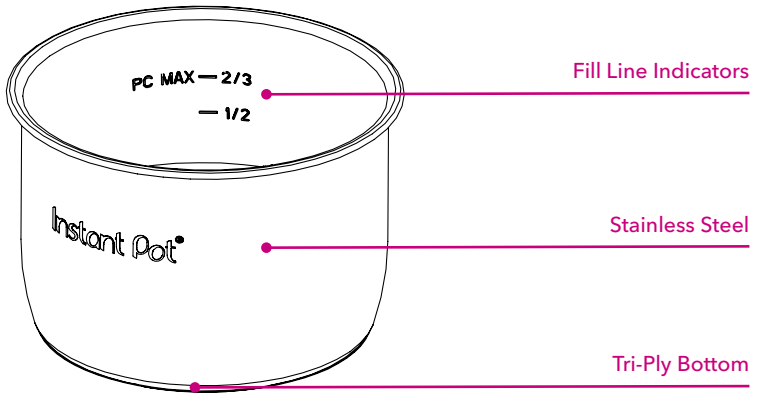

Cooker Base

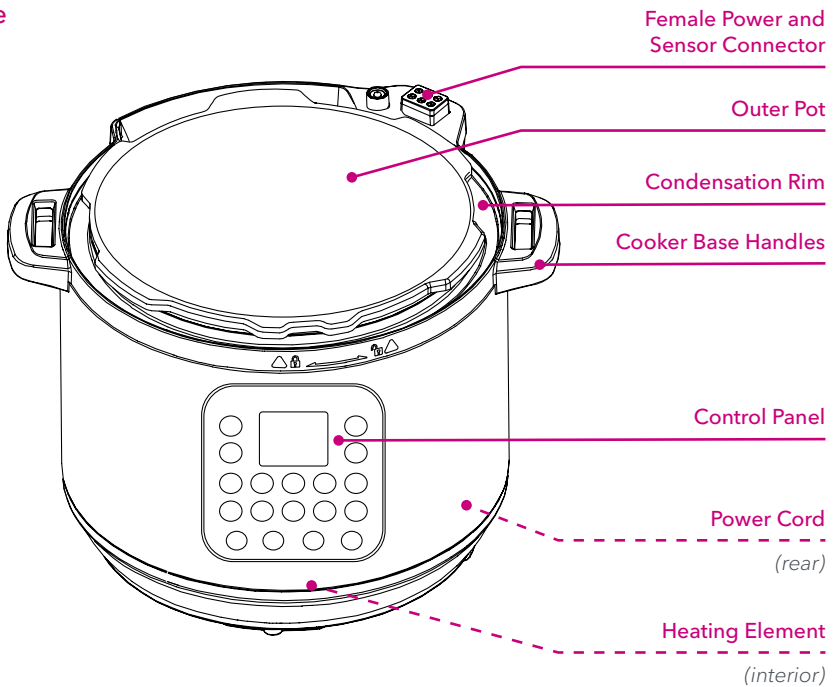

WARNING

The inner pot must always be used when pressure cooking or air fryer. NEVER place food or liquid in the cooker base. Failure to follow these instructions will result in damage to the cooker.

Illustrations are for reference only and may differ from the actual product.

Product, Parts and Accessories

Accessories

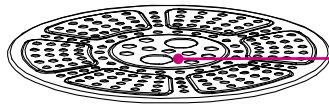

Broil/Dehydrating Tray

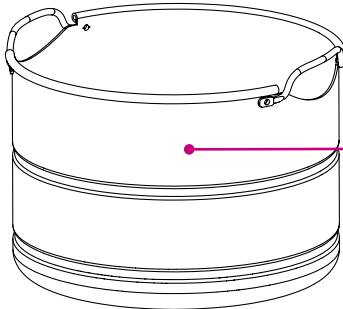

Multi-Level Air Fryer Basket

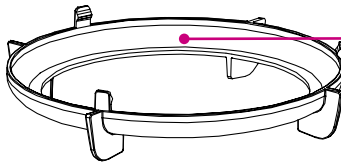

Air Fryer Basket Base

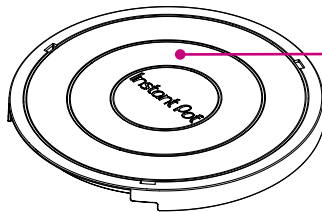

Protective Pad and Storage Cover

Note: Always place the hot air fryer lid on the protective pad.

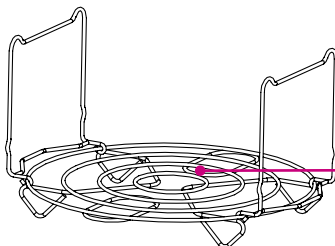

Multi-functional Rack

Illustrations are for reference only and may differ from the actual product.

Product, Parts and Accessories

Lid Standing Position

Did you notice that the cooker base handles have a rectangular slot in them? Keep your counters dry after lifting the pressure cooking lid by inserting the left or right lid fin into the corresponding slot on the cooker base.

Once the lid is safely in the standing position, it's easy to remove the inner pot.

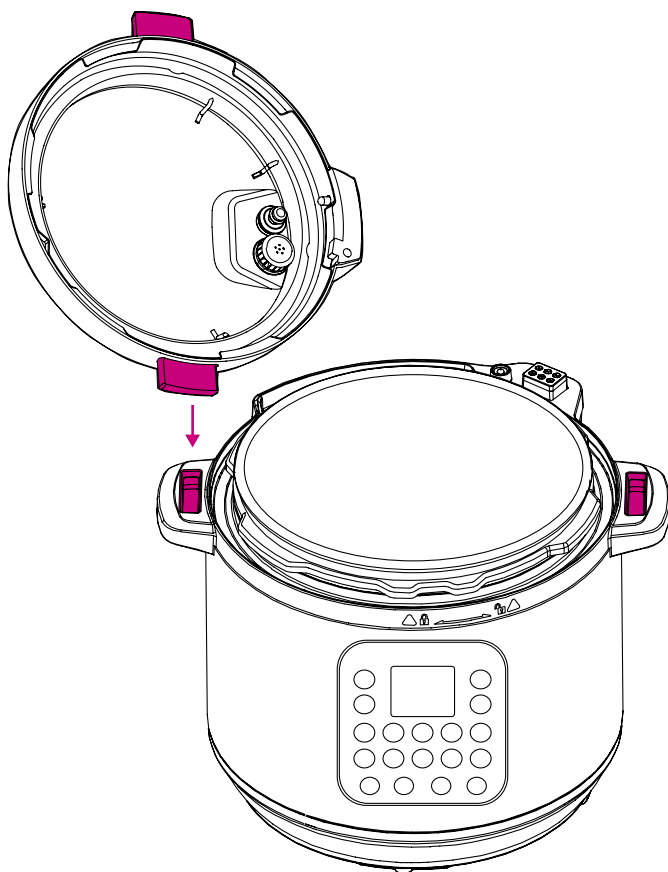

Illustrations are for reference only and may differ from the actual product.

Control Panel

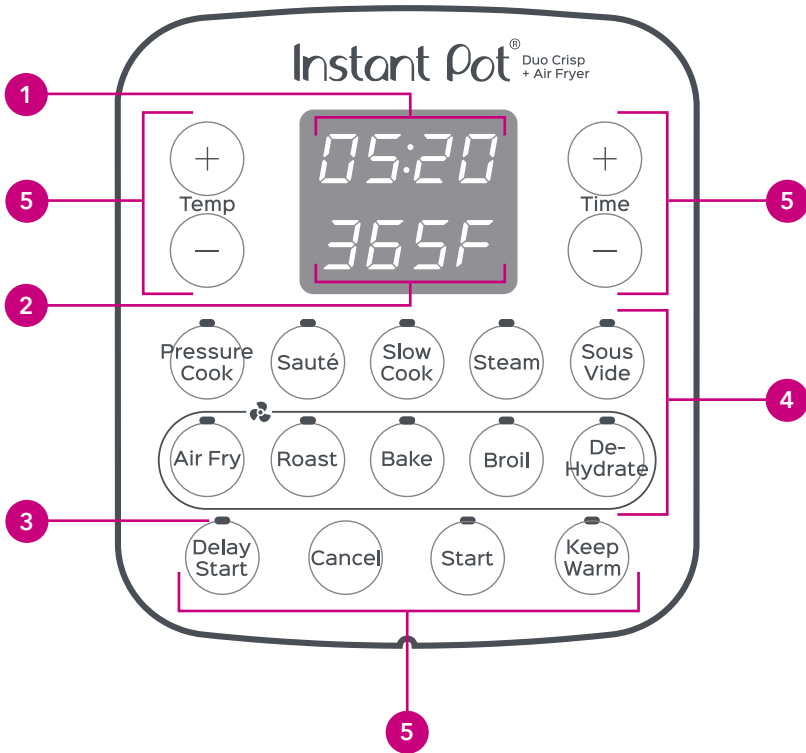

1 Time Display

The countdown timer indicates cooking and Delay Start time in hour format (05:20 is 5 hours, 20 minutes).

The timer counts up while in Keep Warm.

2 Temperature / Pressure Display

Pressure Cooking Lid: Display indicates Lo (Low) or Hi (High) pressure or temperature level.

Note: When using the Sous Vide Smart Program, the display indicates temperature in °F (Fahrenheit) or °C (Celsius).

Air Fryer Lid: Display indicates temperature in °F (Fahrenheit) or °C (Celsius).

3 LED Indicators

Illuminate to indicate the active Smart Program and settings selected.

Note: Steam may range in opacity but is always loud!

Control Panel

4 Smart Programs

Pressure Cooking Lid:

- Pressure Cook
- Sauté
- Slow Cook
- Steam
- Sous Vide

Air Fryer Lid:

- Air Fry
- Roast
- Bake
- Broil
- Dehydrate

5 Smart Program Settings

- + / - Temp
- + / - Time
- Delay Start
- Keep Warm
- Cancel
- Start

Smart Program Settings

Cancel and Standby Mode

Press **Cancel** to stop a Smart Program at any time. The display returns to Standby mode and indicates **OFF**.

Turn Sound On/Off

When in Standby mode, press and hold **+** over **Time** until the display indicates **S On** (sound on) or **SOFF** (sound off).

Note: Error alerts cannot be silenced.

Adjust Temperature Scale: °F or °C

When in Standby mode, press and hold **+** above **Temp** until the display indicates °F (Fahrenheit) or °C (Celsius). The temperature is displayed in the unit indicated.

Set a Delay Start Timer

Delay Start may be applied to the Pressure Cook, Slow Cook and Steam Smart Programs.

Set Delay Start for a minimum of **10** minutes to a maximum of **24** hours.

1. Select a Smart Program and adjust the settings as you desire, then press **Delay Start**.

Note: Once Delay Start has been selected, there is no way to return to the cooking settings. To adjust Smart Program settings, press Cancel and enter new selections.

2. When the timer flashes, use the **+** / **-** Time buttons to adjust the delay time. E.g., 02:00 indicates that cooking will start after 2 hours.
3. Press **Delay Start** again to toggle to the **minutes** field and follow the same process as the previous step.
4. Press **Start** to begin.
The timer begins counting down.
5. When Delay Start reaches **00:00** the Smart Program begins.
The display indicates **On** and the cooker starts to Pre-heat.

Automatically Keep Food Warm After Cooking

Keep Warm is on by default on the Pressure Cook, Slow Cook and Steam Smart Programs.

To turn automatic warming off, select an applicable Smart Program then press **Keep Warm**. The LED indicator dims to indicate that the setting is off.

Smart Program Settings

Reheat Food or Keep Warm for Long Periods

Keep Warm may be set from a minimum of **10** minutes to a maximum of **24** hours.

1. When in Standby, select **Keep Warm**.
2. Press **Keep Warm** again to cycle through **Lo** (Low) and **Hi** (High) temperature levels.
3. Use the **- / + Time** buttons to set a warming timer.
4. Press **Start** to begin.
5. When Keep Warm completes, the display indicates **End**.

Adjust and Save Custom Temperatures

Applicable to Sous Vide, Air Fry, Roast, Bake, Broil and Dehydrate Smart Programs.

1. Select an applicable Smart Program.
2. Use the **- / + Temp** buttons to adjust the temperature in °F or °C.
3. Press **Start** to start the program and save the temperature.

The next time the Smart Program is selected, the new temperature is displayed.

When air frying, the cooking temperature may be adjusted at any time with the **- / + Temp** buttons. Adjustments made after cooking begins are not saved.

Reset Smart Programs to Factory Default Settings

Reset Individual Smart Program

With the cooker in Standby mode, press and hold one Smart Program button until the cooker returns to Standby, it will beep and display **OFF**.

The Smart Program's pressure level, cooking time and temperature are restored to the factory default setting.

Reset All Smart Programs

With the cooker in Standby mode, press and hold **Cancel** until the cooker beeps.

All Smart Program pressure levels, cooking times and temperatures are restored to the factory default setting.

Status Messages

OFF

Indicates that the cooker is in **Standby** mode.

On

Indicates that the cooker is in **Pre-heat** mode.

Lid

May indicate that the lid is missing, not properly secured, or that the wrong lid is being used for the Smart Program selected.

05:20

Display timer indicates one of the following:

- When a Smart Program is running, the display timer counts down to indicate the cooking time remaining in the Smart Program.
- When **Delay Start is running**, the display timer counts down until the Smart Program begins.
- When **Keep Warm is running**, the display timer counts up to indicate how long food has been warming.

Hot

Indicates that the Sauté Smart Program has reached cooking temperature and food may be added to the inner pot.

End

Indicates that a Smart Program has ended and Keep Warm is off.

Food
burn

Indicates overheating in the cooking chamber. Refer to [Troubleshooting](#).

E

Indicates that an error has occurred. Refer to [Troubleshooting](#).

Cleaning Before First Use

Remove the inner pot from the cooker base and wash it with hot water and dish soap. Rinse with warm, clear water and use a soft cloth to dry the outside of the inner pot.

Note: The inner pot is dishwasher safe.

Wipe the heating element with a soft cloth to ensure there are no stray packaging particles present before returning the inner pot to the cooker base.

Note: Before cooking, always ensure the heating element is clean and dry before inserting the inner pot into the cooker base. Failure to do so may damage the cooker.

The inner pot is an integral part of product safety. **Food must be placed in the inner pot, and never directly in the cooker base.**

To avoid personal injury or damage to the appliance, replace a deformed or damaged inner pot. Use only authorized Instant Pot inner pots made for this model when cooking.

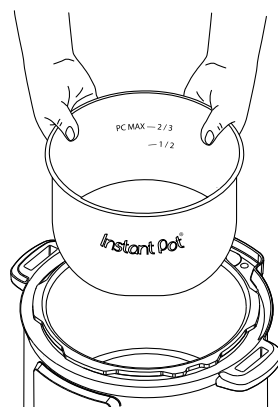
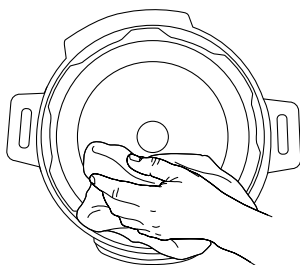
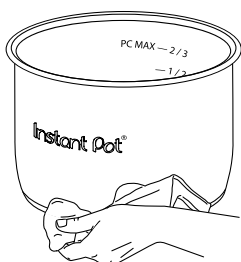

CAUTION

To avoid risk of personal injury and/or property damage, as well as damage to the cooker, do not pour food or liquid into cooker base.

WARNING

Do not fill the inner pot higher than the **PC MAX - 2/3** (Pressure Cooking Maximum), as indicated on the inner pot.

Exercise extreme caution when cooking and venting food such as applesauce, cranberries, pearl barley, oatmeal, split peas, noodles, etc., as these foods may foam, froth, or spatter, and may clog the steam release pipe and/or steam release valve. Do not fill the inner pot higher than the **- 1/2** line when cooking these foods.

Cleaning Before First Use

Accessories

Wash the accessories with hot water and dish soap before using them for the first time, and then after each use. Rinse with warm, clear water and use a soft cloth to dry the accessories.

To assemble the multi-level air fryer basket:

1. Place the multi-level air fryer basket base on a stable surface.
2. Position the air fryer basket over the base and press down firmly. The teeth on the base should pop into the groove on the outside of the basket.
3. To easily lift and position the broil/dehydrating tray, hold the large holes in the middle of the tray with 2 fingers.
4. Insert the broil/dehydrating tray into the multi-level air fryer basket, ensuring that the raised rim is facing down.

Note: *The air fryer basket must be used with the stainless steel inner pot.*

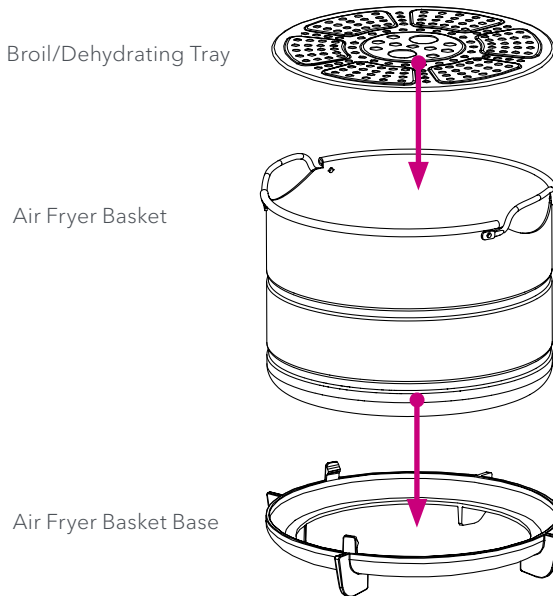

Overview of Pressure Control Features

Pressure Cooking Lid

The stainless steel lid included is necessary for most cooking processes, and is essential for pressure cooking. Always ensure to only use the Duo Crisp pressure cooking lid with the Duo Crisp cooker base.

When plugged in, the cooker plays a jingle when the lid is opened and closed.

Open and Remove the Lid

Grip the lid handle and turn it counter-clockwise to align the ▼ symbol on the lid with the 🔒▲ symbol on the rim of the cooker base, then lift the lid up and off the cooker base.

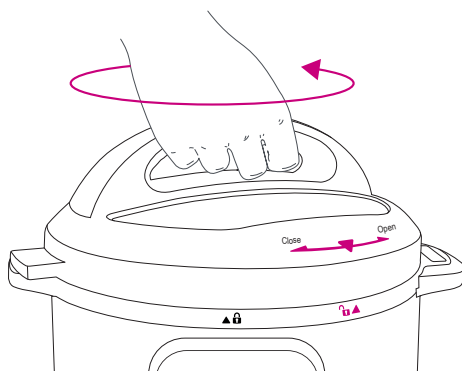

Close the Lid

Align the ▼ symbol on the lid with the 🔒▲ symbol on the cooker base, and lower the lid onto the track. Turn the lid clockwise until the ▼ symbol on the lid aligns with the ▲🔒 symbol on the cooker base.

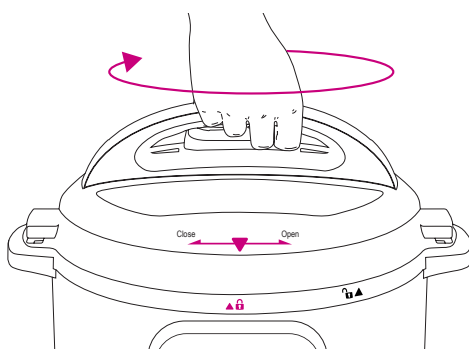

Overview of Pressure Control Features

The pressure cooking lid **automatically seals** for easy pressure cooking, **but does not lock into place when closed**. The lid can be removed during Pre-heating but **locks into place once the cooker has pressurized**

Refer to [Overview of Pressure Control Features–Float Valve](#) for information on pressurization and depressurization.

⚠ DANGER Do not attempt to remove the lid while the float valve is up.

⚠ CAUTION Always check the lid for damage and excessive wear prior to cooking.

⚠ WARNING Use only the Instant Pot Duo Crisp lid with the Instant Pot Duo Crisp pressure cooker base. Using any other pressure cooker lids may cause injury and/or damage.

Quick Release Button

The quick release button controls the steam release valve, sealing and venting the cooker as you desire.

Refer to [Depressurizing the Cooker \(Venting Methods\)](#) for details on safe depressurization.

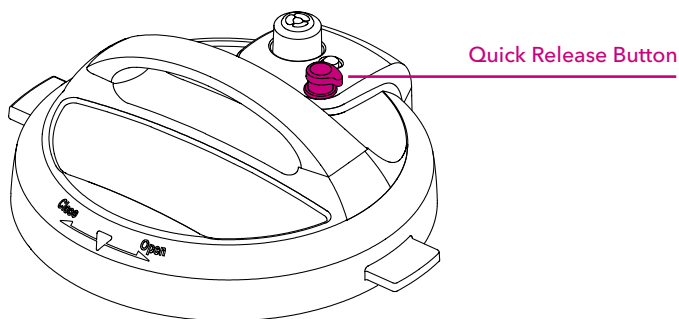

Overview of Pressure Control Features

Steam Release Valve

The steam release valve sits loosely on the steam release pipe. When the cooker releases pressure, steam ejects from the top of the steam release valve.

The steam release valve is integral to product safety and necessary for pressure cooking. It must be installed before use and cleaned regularly.

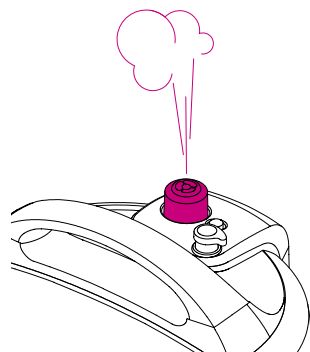

Remove the Steam Release Valve

Pull steam release valve up and off steam release pipe.

Steam release valve must be installed before use and cleaned frequently.

Install the Steam Release Valve

Place the steam release valve on the steam release pipe and press down firmly.

The steam release valve sits loosely on the steam release pipe when installed properly but should remain in place when the lid is turned over.

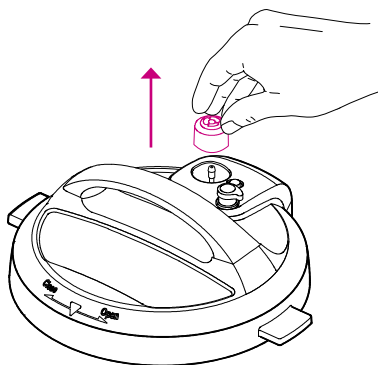

Remove

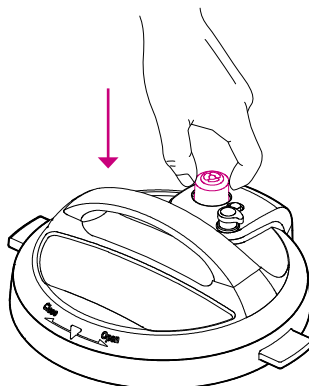

Install



WARNING

Do not cover or block the steam release valve.

Overview of Pressure Control Features

Anti-Block Shield

The anti-block shield prevents food particles from coming up through the steam release pipe, assisting with pressure regulation.

As an integral part of product safety, the anti-block shield must be installed before use and cleaned frequently.

Remove the Anti-Block Shield

Grip the lid like a steering wheel and use your thumbs to press firmly against the side of the anti-block shield (pressing towards the side of the lid and up) until it pops off the prongs underneath.

Install the Anti-Block Shield

Place anti-block shield over prongs and press down until it snaps into position.

Do not attempt to operate the pressure cooker without the anti-block shield installed.

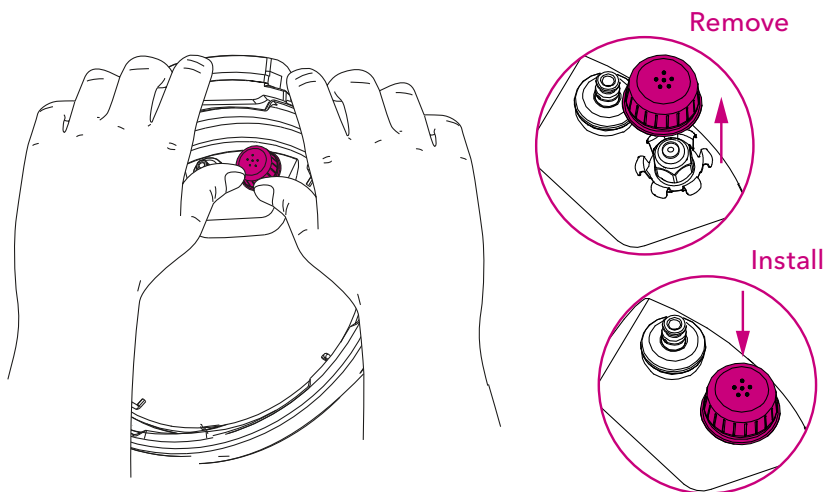

Overview of Pressure Control Features

Sealing Ring

When the pressure cooking lid is closed, the sealing ring installed on the underside of the lid creates an air-tight seal between the lid and the cooker base.

The sealing ring must be installed before using the cooker and should be cleaned after each use. Only 1 sealing ring should be installed in the lid when using the cooker. Use one for sweet dishes and one for savory.

Sealing rings stretch over time with normal use. As an integral part of product safety, the sealing ring should be replaced every 12-18 months or sooner if stretching, deformation, or damage is noticed.

Remove the Sealing Ring

Grip the edge of the silicone and pull the sealing ring out from behind the circular stainless steel sealing ring rack.

With the sealing ring removed, inspect the rack to ensure it is secured, centered, and an even height all the way around the lid. Do not attempt to repair a deformed sealing ring rack.

Install the Sealing Ring

Place the sealing ring over the sealing ring rack and press it into place. Press down firmly to ensure there is no puckering.

When installed properly, the sealing ring is snug behind sealing ring rack and should not fall out when the lid is turned over.

Remove

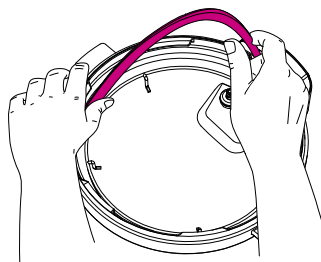

Install

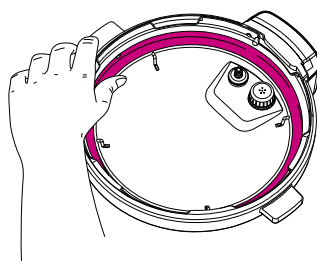

Incorrect

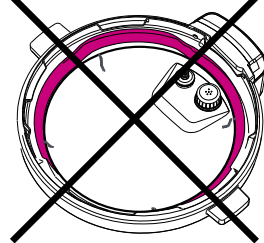

Instant Tip: Silicone is porous, so it may absorb strong aromas and certain flavors. Keep extra sealing rings on hand to limit the transfer of those aromas and flavors between dishes. Visit [our store](#) to color code your cooking.

CAUTION

Always check for cuts, deformation, and correct installation of the sealing ring prior to cooking. Do not use a stretched or damaged sealing ring. Only use authorized Instant Pot sealing rings. Failure to follow these instructions may cause food to discharge, which may lead to personal injury or property damage.

Overview of Pressure Control Features

Float Valve

The float valve provides a visual indication of pressure within the cooker and appears in 2 positions.

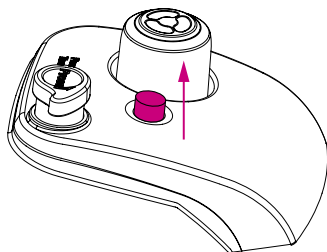

Pressurized

The float valve has visibly popped up above the surface of the lid.

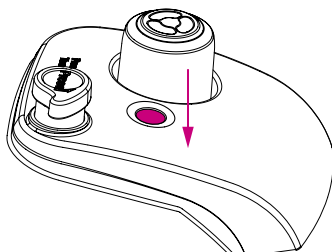

Depressurized

The float valve has descended and the top is flush with the lid.

The float valve and silicone cap work together to seal in pressurized steam. These parts must be installed before use and should be cleaned after each use.

⚠ DANGER

While the float valve is up, contents of cooker are under extreme pressure. **Do not attempt to remove the lid.** All pressure **must** be released, and float valve must be **down**. Refer to [Depressurizing the Cooker \(Venting Methods\)](#) for information on releasing pressure. Failure to follow these instructions may result in property damage and/or personal injury.

Remove the Float Valve from the Lid

Place one finger on the flat top of float valve, then turn the lid over. Detach the silicone cap from the bottom side of the float valve.

Remove the float valve from the top of the lid. Do not discard the float valve or silicone cap.

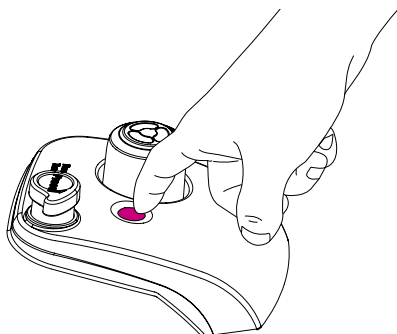

Top

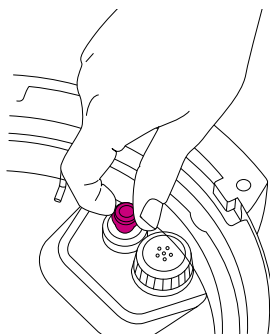

Bottom

Overview of Pressure Control Features

Install the Float Valve

Drop the narrow end of the float valve into the float valve hole on the top of the lid. Place one finger on the flat top of the float valve, then turn the lid over. Firmly attach the silicone cap to the bottom of the float valve.

Do not attempt to operate the pressure cooker without the float valve and/or silicone cap properly installed in the pressure cooking lid.

Condensation Collector

The condensation collector sits at the back of the cooker base and accumulates overflow moisture from the condensation rim. It should be installed before cooking, then emptied and rinsed out after each use.

Remove the Condensation Collector

Pull the condensation collector away from the cooker base; do not pull down. Note the tabs on the cooker base and the grooves on the condensation collector.

Install the Condensation Collector

Align the grooves on the condensation collector over the tabs on the back of the cooker base and slide the condensation collector into place.

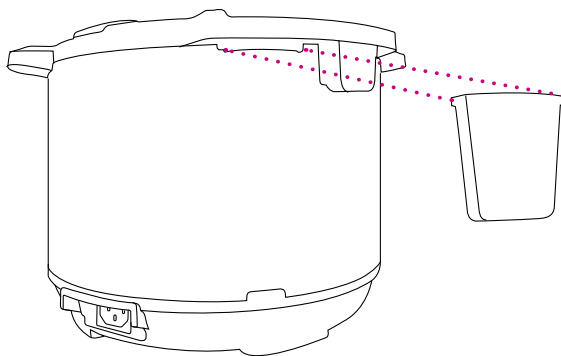

Introduction to Pressure Cooking

Pressure cooking uses steam pressure to raise the boiling point of water above 100°C / 212°F. This energy-efficient cooking method is the fastest way to thoroughly cook a variety of your favorite meals.

Pressure cookers go through 3 stages when pressure cooking:

1. Pre-Heating and Pressurization

After you have finished inputting your selections press **Start** to begin. The display reads **On** to indicate it has begun pre-heating. While the cooker pre-heats, it vaporizes liquid in the inner pot to create steam. Once enough steam has built up inside the inner pot, the float valve pops up and locks the lid of the cooker in place for safe pressure cooking.

When the float valve pops up, the silicone cap attached to the bottom of the float valve (on the underside of the lid) seals the steam inside the cooking chamber (the inner pot) and allows the pressure to rise even higher. A higher pressure means a higher cooking temperature.

While it is normal to see some steam escaping through the float valve during Pre-Heating, if you see steam escaping from around the sides of the lid, press **Cancel** and refer to [Troubleshooting](#).

Note: The time it takes your cooker to pressurize is determined by a variety of factors, including food and liquid volume.

2. Cooking

After the float valve pops up, the cooker needs a few minutes to finish building pressure. When the required pressure level is reached, cooking begins. The display switches from **On** to the cooking countdown timer, displayed in **HH:MM** (hours : minutes) format.

Smart Program settings (e.g., cooking time, temperature and/or pressure level, and whether **Keep Warm** will come on automatically or not) can be adjusted at any time during cooking. Refer to [Smart Program Settings](#) for details.

Introduction to Pressure Cooking

3. Depressurization

After pressure cooking completes, follow your recipe instructions for depressurizing the cooker.

If automatic Keep Warm is on after cooking completes, the timer counts up from **00:00** to indicate the elapsed time up to **10** hours. If not, the cooker returns to Standby and displays **End**.

Note: The cooker cools and depressurizes faster if automatic Keep Warm is off.

See [Depressurizing the Cooker \(Venting Methods\)](#) for information on releasing pressure after cooking.

⚠ DANGER

While the float valve is up, contents of cooker are under extreme pressure. **Do not attempt to remove the lid while the float valve is still up.** All pressure **must** be released, and float valve must be **down** before attempting to remove the lid. **Never attempt to force the lid open.** Failure to follow the instructions may result in property damage and/or personal injury.

Depressurizing the Cooker (Venting Methods)

Always follow recipe instructions for depressurizing the cooker.

When the cooker has completely depressurized, the float valve drops into the lid as indicated in [Overview of Pressure Control Features–Float Valve](#).

Natural Release (NR)

Leave the quick release button in the popped-up **Seal** position. As the temperature within the cooker drops, the cooker depressurizes naturally over time.



Seal Position

Depressurization time varies based upon the volume and type of food and liquid. When the cooker has completely depressurized, the float valve drops into the lid.

NOTICE

Use NR to depressurize the cooker after cooking high-starch foods (e.g., soups, stews, chilis, pasta, oatmeal and congee) or after cooking foods that expand when cooked (e.g., beans and grains).

Quick Release (QR)

Press the quick release button down until it clicks and locks into the **Vent** position.

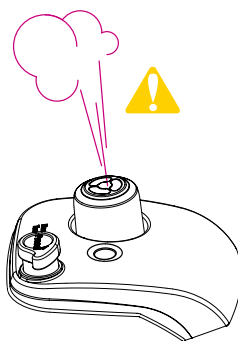
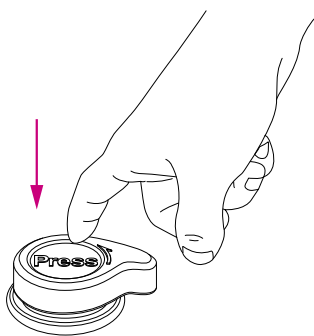

When depressed, a stream of steam releases through the top of the steam release valve.

Note: Steam may range in opacity but is always loud!

CAUTION

Steam ejected from the steam release valve is hot. Do not place hands, face, or any exposed skin over the steam release valve when releasing pressure.

Depressurizing the Cooker (Venting Methods)

If continuous spatter occurs while venting, set the cooker back to **Seal** by flicking the quick release button. The button pops back up to indicate that it is sealed and stops the depressurization process. Wait a few minutes before trying to QR again. If spatter continues, use NR to safely release remaining pressure.

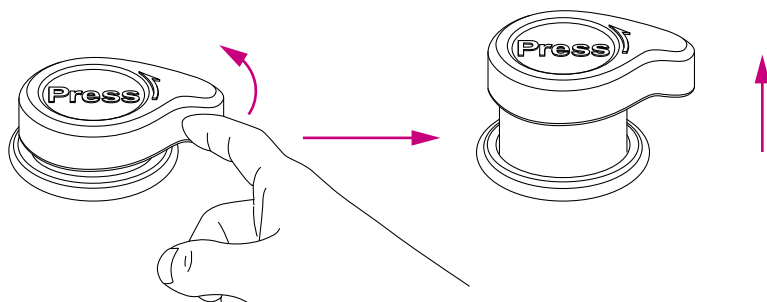

NOTICE

Do not use QR when cooking high-starch foods (e.g., stews, chilis, pasta and congee) or when cooking foods that expand when cooked (e.g., beans and grains).

10-Minute NR

Leave the quick release button in the popped-up **Seal** position for **10** minutes after cooking has completed, then press the quick release button down until it clicks and locks into the **Vent** position. When depressed, a stream of steam releases through the top of the steam release valve.

If continuous spatter occurs while venting, set the cooker back to **Seal** by flicking the quick release button. Wait an additional 5 minutes before trying to QR again. If spatter continues, use NR to safely release remaining pressure.

⚠ DANGER

While the float valve is up, contents of cooker are under **extreme pressure**. **Do not attempt to remove the lid while the float valve is still up**. All pressure **must** be released, and float valve **must** be down before attempting to remove the lid. **Never attempt to force the lid open**. Failure to follow the instructions may result in property damage and/or personal injury.

⚠ WARNING

Do not lean over or touch the steam release valve.

Do not place unprotected skin over the steam release valve.

Do not cover or obstruct the steam release valve.

Initial Test Run (Water Test)

Follow these steps to start familiarizing yourself with your Instant Pot Duo Crisp + Air Fryer.

Note: Always ensure you are using the stainless steel inner pot when pressure cooking or air frying. NEVER place food or liquid into the cooker base.

Total test time: Approximately 20 minutes.

1. Remove the inner pot from the cooker base.
2. Add 3 cups (24 oz / 750 mL) of water to the inner pot.
3. Insert the inner pot into the cooker base.
4. Connect the power cord to a 120 V power source. The display indicates **OFF**.
5. Place and close the lid as described in [Pressure Control Features–Pressure Cooking Lid](#).

Note: The lid automatically seals for pressure cooking.

6. Press **Pressure Cook** to select the Pressure Cook Smart Program.
7. Use the **+ / – Time** buttons to adjust the cooking time to **5** minutes.

Note: Cooking time adjustments are saved to the Smart Program when cooking begins.

8. Press **Keep Warm** to deactivate the automatic Keep Warm setting.
9. Press **Start** to begin. The display reads **On** to indicate that the cooker has begun **Pre-heating**.

Note: To understand how pressure cooking works, read [Introduction to Pressure Cooking](#) while the cooker heats.

10. The float valve rises when the cooker has pressurized. After a few minutes the cooker reaches the target pressure level and **Cooking** begins. The display changes from **On** to the cook time countdown.
11. When the Smart Program is complete, the display indicates **End**.
12. Press the quick release button down until it clicks into the **Vent** position. Pressurized steam releases through the top of the steam release valve.
13. The float valve drops when the pressure has been fully released.
14. Open and remove the lid as described in [Pressure Control Features–Pressure Cooking Lid](#).
15. Carefully remove the inner pot from the cooker base, discard the water and thoroughly dry the inner pot.

You're ready to start cooking!



The inner pot will be hot after cooking. Always use appropriate heat protection when handling a hot inner pot.

Smart Programs: Non Air Frying

Whether you are a novice cook or a culinary expert, the Duo Crisp + Air Fryer provides Smart Programs to get you cooking—fast!

All oven-safe cookware is safe for use in the inner pot, and the included air frying accessories feature multiple levels to suit your cooking needs.

Always inspect your Instant Pot pressure cooking lid, inner pot and cooker base carefully to ensure they are clean and in good working condition before use.

Pressure Cook and Steam

The Pressure Cook and Steam Smart Programs are pressure cooking programs. Using pressurized steam ensures your dish is cooked evenly and deeply, for predictably delicious results every time.

The Duo Crisp features 2 pressure levels to choose from:

Pressure Level	Suggested Use	Default Cooking Time	Cooking Time Range
Lo (Low) 5.8-7.2 psi (35-55 kPa)	Fish and seafood, soft vegetables, rice	Pressure Cook: 00:35 Steam: 00:30	00:00-04:00
Hi (High) 10.2-11.6 psi (65-85 kPa)	Eggs, meat, poultry, roots and other hard vegetables, oats, beans, grains, bone broth, chili		

Because the pressure level controls the temperature, a higher pressure results in a higher cooking temperature.

Pressure cooking liquids should be water-based, such as broth, stock, soup or juice. If using canned, condensed, or cream-based soup, add water as directed below.

Instant Tip: Using the multifunctional rack will ensure your food items are steamed and not boiled. This provides even heat distribution, prevents nutrients from leeching into the cooking liquid, and stops food items from scorching on the bottom of the inner pot.

Instant Pot Size	Minimum Liquid for Pressure Cooking*
6 Quarts / 5.7 Litres	1.5 cups (12 oz / 375 mL)
8 Quarts / 7.6 Litres	2 cups (16 oz / 500 mL)

**Unless otherwise specified in recipe.*

CAUTION

To avoid scorching or scalding injury, be cautious when cooking with more than 1/4 cup (2 oz / 60 mL) oil, oil-based sauces, condensed cream-based soups, and thick sauces. Add suitable liquid to thin sauces. Avoid recipes that call for more than 1/4 cup (2 oz / 60 mL) of oil or fat content.

Smart Programs: Non Air Frying

1. Place the steam rack on the bottom of the inner pot.
2. According to your recipe, add liquid to the inner pot, then place food ingredients on the steam rack.
Note: Cold or frozen food items take longer to generate steam and slow down pressurization. For the fastest results, thaw frozen ingredients before cooking.
Note: When cooking beans or grains, refer to the [Grain-to-Water Ratios](#) for best results.
3. Insert the inner pot into the cooker base.
4. Connect the power cord to a 120 V power source. The cooker goes to Standby mode and the display indicates **OFF**.
5. Place and close the lid as described in "[Pressure Control Features—Pressure Cooking Lid](#)".
Note: The quick release button will automatically pop up to the Seal position for pressure cooking.
6. To select the Smart Program, press either **Pressure Cook** or **Steam**.
7. You may select the default cooking time, or, use the **+ / – Time** buttons to create a customized cooking time.
Note: Adjustments to the cooking time and pressure level are saved when you press Start.
8. Press the same Smart Program button again to toggle between **Lo** (Low) and **Hi** (High) pressure levels.
9. Press **Keep Warm** to toggle the automatic Keep Warm setting off or on, as you desire. Refer to [Automatically Keep Food Warm After Cooking](#) for details.
10. Press **Start** to begin. The display reads **On** to indicate that the cooker has begun **Pre-heating**.
11. If Keep Warm mode is on when the Smart Program completes, the cooker counts up to indicate the elapsed time. If not, the cooker goes to Standby mode and the display indicates **End**.

Follow the recipe directions to select the appropriate venting method. Refer to [Depressurizing the Cooker \(Venting Methods\)](#).

Instant Tip: If you prefer, you may use an Instant Pot tempered glass lid with the Steam or Slow Cook Smart Programs. Visit [our store](#) for purchasing details.

Smart Programs: Non Air Frying

DANGER

While the float valve is up, contents of cooker are under extreme pressure. **Do not attempt to remove the lid while the float valve is still up.** All pressure **must** be released, and float valve must be **down** before attempting to remove the lid. **Never attempt to force the lid open.** Failure to follow the instructions may result in property damage and/or personal injury.

WARNING

Do not fill inner pot higher than the **PC MAX — 2/3** line as indicated on the inner pot.

When cooking foods that expand (e.g.: rice, beans, pasta) do not fill the inner pot higher than the **— 1/2** line as indicated on the inner pot.

Always cook with the inner pot in place. Do not pour food or liquid into the cooker base.

To avoid risk of personal injury and/or property damage, place food and liquid ingredients in the inner pot, then insert the inner pot into the cooker base.

Smart Programs: Non Air Frying

Sauté

The Sauté Smart Program is similar to using a frying pan, griddle, or flat-top grill. Use Sauté to simmer, reduce and thicken liquids, stir-fry meals, and to caramelize vegetables and sear meat before or after cooking.

Sautéing meat and vegetables before pressure cooking is the perfect way to boost flavors, and deglazing can help give your recipes extra depth. Refer to [Deglazing the Inner Pot](#) for details.

Temperature Level	Suggested Use	Default Cooking Time	Cooking Time Range
Lo (Low)	Simmer, reduce, thicken and caramelize	00:30	00:01-00:30
Hi (High)	Pan sear, stir-fry, sauté and brown		

Delay Start and Keep Warm settings are not available on the Sauté Smart Program.

1. Ensure the inner pot is in position in the cooker base. **Do not use a lid.**
2. Connect the power cord to a 120 V power source. The cooker goes to Standby mode and the display indicates **OFF**.
3. Press **Sauté** to select the Sauté Smart Program.
4. You may select the default cooking time, or use the **+ / - Time** buttons to select a customized cooking time.
5. Press **Sauté** again to toggle between **Lo** (Low) and **Hi** (High) temperature levels.

Note: Adjustments to the cooking time and temperature level are saved when you press Start.

6. Press **Start** to begin. The display reads **On** to indicate that the cooker has begun **Pre-heating**.
7. When the display switches from **On** to **Hot**, it has reached the target temperature.

Note: Add ingredients to the inner pot according to your recipe. If recipe ingredients are added before the Hot message appears, it may not appear at all. This is normal.

8. When the Smart Program completes, the display indicates **End**.

*Note: If the ingredients have been sautéed to the desired doneness before the time expires, press **Cancel** to end the Smart Program.*

Smart Programs: Non Air Frying

Deglazing the Inner Pot (Pressure Cooking After Sauté)

When the Sauté Smart Program has completed, carefully remove food items from the inner pot and add cold liquid (e.g., juice, vinegar, broth, wine, etc.) to the hot surface.

Use a wooden or silicone scraper to loosen anything that may be stuck to the bottom of the inner pot, adding liquid as necessary.

This liquid is packed with flavor and can be used as a base for gravies and sauces. If desired, you may use the Sauté Smart Program to further reduce the deglazing liquid.

⚠ CAUTION

The Sauté Smart Program reaches high temperatures. If unmonitored, food may burn on this setting. Do not use the lid and do not leave your cooker unattended while using Sauté.

Smart Programs: Non Air Frying

Slow Cook

The Slow Cook Smart Program is comparable to the cooking process of traditional slow cookers, and is compatible for use with any common slow cooker recipe. Follow recipe directions for slow cooking.

Temperature Level	Suggested Use	Default Cooking Time	Cooking Time Range
Lo (Low)	All-day cooking. Set for a minimum of 06:00 hours for best results	06:00	00:30-24:00
Hi (High)	Faster slow cooking		

1. Add food and liquid ingredients to the inner pot.
2. Insert the inner pot into the cooker base.
3. Connect the power cord to a 120 V power source. The cooker goes to Standby mode and the display indicates **OFF**.
4. Place and close the lid as described in [Pressure Control Features–Pressure Cooking Lid](#) or use a glass lid with a venting hole.
5. Press the quick release button down until it clicks and locks into the **Vent** position.
6. Press **Slow Cook** to select the Slow Cook Smart Program.
7. You may select the default cooking time, or use the **+ / – Time** buttons to select a customized cooking time.
8. Press **Slow Cook** again to toggle between **Lo** (Low) and **Hi** (High) temperature levels.
Note: Adjustments to the cooking time and temperature level are saved when you press Start.
9. If desired, press **Keep Warm** to toggle the automatic Keep Warm setting off or on.
10. Press **Start** to begin. The cooking timer begins counting down immediately.
11. If Keep Warm mode is on when the Smart Program completes, the cooker counts up to indicate the elapsed time. If not, the cooker goes to Standby mode and the display indicates **End**.

Note: The float valve should not rise during Slow Cook. The lid is removable throughout the cooking process for easy access. If the float valve rises, ensure the quick release button is set to the **Vent** position. Refer to [Depressurizing the Cooker \(Venting Methods\)](#).

Smart Programs: Non Air Frying

Sous Vide

Sous Vide cooking brings vacuum-sealed food to a very accurate temperature and maintains that temperature for a long period of time to achieve high quality, consistently delicious results.

Default Temperature	Temperature Range	Suggested Use	Default Cooking Time	Cooking Time Range
133°F / 56°C	70°F-200°F / 21°C-93°C	Refer to "Sous Vide Cooking Guidelines" for details	03:00	00:30-99:30

What You'll Need:

- Tongs
- Thermometer
- Airtight or Vacuum Sealed Food Pouches
- Optional: Vacuum sealer

1. Fill the inner pot with warm water up to **-1/2** line, as indicated on the inner pot.
2. Insert the inner pot into the cooker base.
3. Connect the power cord to a 120 V power source. The cooker goes to Standby mode and the display indicates **OFF**.
4. Place and close the lid as described in [Pressure Control Features—Pressure Cooking Lid](#).

***Note:** The quick release switch will automatically set to Seal when the lid is closed. For Sous Vide it does not matter if the quick release switch is set to Seal or Vent.*

***Note:** The pressure cooking lid is not necessary when cooking sous vide, however it is recommended for optimal temperature control.*

5. Press **Sous Vide** to select the Sous Vide Smart Program.
6. Use the **+ / - Temp** buttons to adjust the temperature in increments of 1°C / 1°F.
7. Use the **+ / - Time** buttons to adjust the cook time in increments of 15 minutes.
***Note:** Adjustments to the cooking time and temperature are saved when you press Start.*
8. Press **Start** to begin. The display reads **On** to indicate that the cooker has begun **Pre-heating**.
9. While the cooker heats, season food as desired. Refer to [Ingredients and Seasonings](#).
Separate single servings of food within individual pouches, remove as much air as possible, then seal them tightly.

Smart Programs: Non Air Frying

10. The cooker beeps once the water temperature is reached. Remove the lid and immerse the sealed pouches in the warm water. The pouches contents should be submerged, but the seal should remain above the water line.

CAUTION

Do not overfill the inner pot. Ensure that total contents (water and food pouches) leave at least 2" / 5 cm of space between the brim of the inner pot and the water line.

11. Place and close the lid as described in [Pressure Control Features–Pressure Cooking Lid](#).

Note: For cooking times over 04:00 hours, check the water level periodically to ensure pouch contents remain submerged. If required, add heated water to the inner pot.

12. Once complete, the display indicates **End**. Open cooker and carefully remove the pouches from water.
13. Remove contents from pouches and use a thermometer to check for doneness. Follow a recipe or refer to the [Sous Vide Cooking Guidelines](#).

Reverse Searing

Searing your meat after cooking, rather than before, is a great way to boost flavors.

After sous vide cooking, remove the meat from the cooking pouch and gently pat it dry. Then, sear it lightly in the inner pot with the Sauté Smart Program, or use a pan, browning torch, or grill.

Ingredients and Seasonings

- Use high quality, fresh ingredients when cooking sous vide to ensure the best possible flavor.
- When seasoning with salt, it is better to use less than you might add normally, especially with meats, poultry, and fish. Instead, salt to taste after cooking.
- Use garlic powder rather than raw garlic. Raw garlic can become bitter and overpowering when cooked sous vide. Pure and high-quality garlic powder provides the best results.

Note: Do not use garlic salt in place of garlic powder!

Storing Cooked Food

If your dish is not going to be consumed immediately, plunge pouches into ice water to reduce temperature quickly, then keep refrigerated until ready to consume.

Smart Programs: Non Air Frying

Sous Vide Cooking Guidelines

Food	Recommended Thickness	Expected Doneness	Cooking Temperature	Minimum Cooking Time	Maximum Cooking Time
Beef and Lamb					
Tender Cuts: Tenderloin, cutlets, sirloin, rib-eye, rump, T-bone, chops	2-5 cm / ½"-2"	Rare	122°F / 50°C	1 hour	4 hours
		Medium-rare	129°F / 54°C	1.5 hours	4 hours
Tougher Cuts: Blade, chuck, shoulder, shanks, game meats	4-6 cm / 1½"-2½"	Medium	140°F / 60°C	1.5 hours	4 hours
		Medium-well	145°F / 63°C	1.5 hours	4 hours
Poultry					
Chicken Breast	3-5 cm / 1"-2"	Soft and Juicy	145°F / 63°C	1.5 hours	4 hours
		Traditionally firm	155°F / 69°C	1 hour	4 hours
Chicken Thigh	3-5 cm / 1"-2"	Juicy and tender	165°F / 74°C	1 hour	4 hours
		Off-the-bone tender	165°F / 74°C	4 hours	8 hours
Chicken Leg	5-7 cm / 2"-3"	Juicy and Tender	165°F / 74°C	2 hours	7 hours
Duck Breast	3-5 cm / 1"-2"	Soft and Juicy	146°F / 64°C	2 hours	4 hours
Pork					
Belly	3-6 cm / 1"-2½"	Traditionally firm	180°F / 82°C	10 hours	22 hours
Ribs	2-3 cm / ½"-1½"	Off-the-bone tender	138°F / 59°C	10 hours	22 hours
Chops	2-4 cm / ½"-2"	Pink and juicy	135°F / 57°C	1 hour	4 hours
		White throughout and juicy	147°F / 64°C	1 hour	4 hours

Smart Programs: Non Air Frying

Food	Recommended Thickness	Expected Doneness	Cooking Temperature	Minimum Cooking Time	Maximum Cooking Time
Fish and Seafood					
Fish	2-3 cm / ½"-1½"	Soft and buttery	110°F / 43°C	10 minutes	30 minutes
		Translucent / starts to flake	115°F / 46°C	20 minutes	45 minutes
		Medium-rare	125°F / 52°C	20 minutes	45 minutes
		Medium, dry	130°F / 54°C	20 minutes	45 minutes
		Well-done, crumbly	135°F / 57°C	20 minutes	45 minutes
Shrimp	-	Traditionally firm	140°F / 60°C	30 minutes	45 minutes
Lobster Tail	-	Soft and buttery	140°F / 60°C	1 hour	1 hour
Scallops	-	Soft and buttery	140°F / 60°C	30 minutes	30 minutes
Eggs					
Eggs	Large / Extra Large	Runny	140°F / 60°C	-	45 minutes
		Soft boiled	145°F / 62°C	-	45 minutes
		Medium boiled	150°F / 65°C	-	1 hour
		Hard boiled	165°F / 73.9°C	-	1 hour
Fruits and Vegetables					
Fruits	-	-	183°F / 83.9°C	15 minutes	2 hours
Vegetables	-	-	183°F / 83.9°C	45 minutes	2.5 hours

Smart Programs: Air Frying

The Duo Crisp + Air Fryer uses rapid air circulation to crisp or cook food, giving your meals all the rich, crispy flavor of deep frying, with little to no oil.

There are a few ways to use the air fryer lid for air frying:

1. Give your dish a crispy golden finish after cooking with the Pressure Cook, Slow Cook, Steam or Sous Vide Smart Programs.
2. Cook your dish entirely with the air fryer lid, with the Air Fry, Roast, Bake or Broil Smart Programs.

For best results use the provided air fryer basket, which features multiple levels to suit your cooking needs. All oven-safe cookware is safe to use in the inner pot.

Delay Start and Keep Warm are not available for use with air frying Smart Programs.

NOTICE

Do not crowd the multi-level air fryer basket or the broil/dehydrating tray. Air must be able to circulate freely around food items.

The Air Fryer Lid

After lifting the air fryer lid off the Instant Pot cooker base, always place it on the protection pad provided. Do not rest the air fryer lid on countertops or on its power cord.

To store your air fryer lid, flip the protective pad over so the grooved side faces up. Align the back of the air fryer lid with **OPEN** on the protective pad, then turn the air fryer lid clockwise to the **LOCK** position.

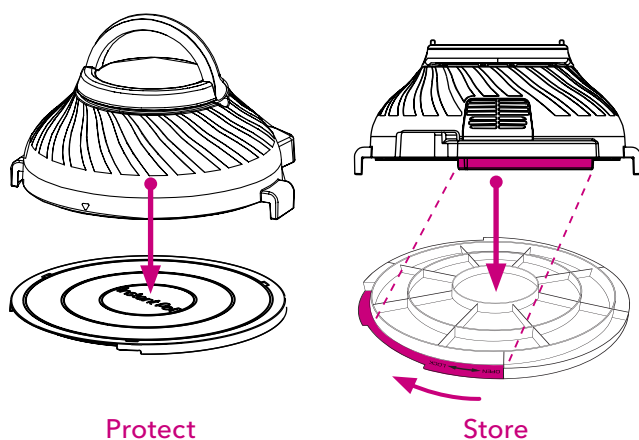

Smart Programs: Air Frying

Air Fry

Air frying is an amazing way to bring out a lot of flavor using only a little oil. Enjoy your favorites without the hassle.

Default Temperature	Temperature Range	Suggested Use	Default Cooking Time	Cooking Time Range
400°F 204°C	180°F-400°F 82°C-204°C	Fresh or frozen fries, chicken wings, shrimp,	00:18	00:01-01:00

1. Insert food into the multi-level air fryer basket, oven-safe cookware, or directly in the inner pot, according to your recipe.
Note: Refer to [Cleaning Before First Use—Accessories](#) for details on assembly.
2. If using an accessory, insert the accessory into the inner pot.
3. Insert the inner pot into the cooker base.
4. Connect the power cord to a 120 V power source. The cooker goes to Standby mode and the display indicates **OFF**.
5. Align the lid fins with the slots in the cooker base handles and lower the lid until a jingle sounds.

Note: Press the lid down slightly to ensure that the lid sensor connector contacts the base sensor connector.

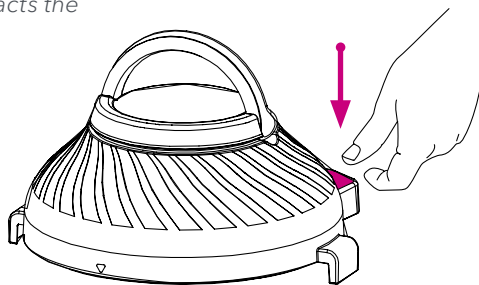

6. Press **Air Fry** to select the Air Fry Smart Program.
7. Use the **+ / - Temp** buttons to adjust the temperature in increments of 1°C / 5°F.
8. Use the **+ / - Time** buttons to adjust the cook time.

Note: Adjustments to the cooking time and temperature are saved when you press Start.

Smart Programs: Air Frying

9. Press **Start** to begin. The display reads **On** to indicate that the cooker has begun Pre-heating.
10. When the cooker reaches the target temperature, **On** changes to the cooking countdown timer.
11. Part way through the cooking cycle the display indicates **turn Food**.
12. Lift the air fryer lid off the Instant Pot cooker base and place it on the protective pad provided.
Note: Lifting the lid automatically pauses cooking for 3 minutes. After 3 minutes the program will stop, and the air fryer lid will go into Standby mode.
13. Carefully turn, flip, or rotate your food.
14. Close the lid as described in step 5.
*Note: Some food does not require turning. If the lid is not removed after the **turn Food** indicator appears, cooking will proceed after 10 seconds.*
15. When there is 1 minute left, the timer counts down the remaining cooking time in seconds.
16. When the Smart Program completes, the lid beeps, and the display indicates **End**.
Note: The air fryer lid beep after 5 minutes, 20 minutes, and 60 minutes to remind you that cooking has completed.

CAUTION

To avoid personal injury or damage to property, only place the lid on the protective pad provided.

WARNING

Do not overfill the inner pot or accessories. To prevent risk of fire, damage or personal injury, ensure that food contents do not make contact with the heating element or the element cover.

WARNING

If the sensor connectors on the air fryer lid and cooker base are not fully connected, the display will indicate C9. Failure to ensure a proper connection could result in damage to the cooker.

Smart Programs: Air Frying

Roast

Default Temperature	Temperature Range	Suggested Use	Default Cooking Time	Cooking Time Range
380°F 193°C	180°F-400°F 82°C-204°C	Beef, lamb, pork, poultry, vegetables, scalloped potatoes and more	00:40	00:01-01:00

1. Insert food into the multi-level air fryer basket, oven-safe cookware, or directly in the inner pot, according to your recipe.

Note: Refer to [Cleaning Before First Use—Accessories](#) for details on assembly.

2. If using an accessory, insert the accessory into the inner pot.
3. Insert the inner pot into the cooker base.
4. Connect the power cord to a 120 V power source. The cooker goes to Standby mode and the display indicates **OFF**.
5. Align the lid fins with the slots in the cooker base handles and lower the lid until a jingle sounds.

Note: Press the lid down slightly to ensure that the lid sensor connector contacts the base sensor connector.

6. Press **Roast** to select the Roast Smart Program.
7. Use the **+ / - Temp** buttons to adjust the temperature in increments of 1°C / 5°F.
8. Use the **+ / - Time** buttons to adjust the cook time.

Note: Adjustments to the cooking time and temperature are saved when you press **Start**.

9. Press **Start** to begin. The display reads **On** to indicate that the cooker has begun Pre-heating.
10. When the cooker reaches the target temperature, **On** changes to the cooking countdown timer.
11. Part way through the cooking cycle, the display indicates **turn Food**.
12. Lift the air fryer lid off the Instant Pot cooker base and place it on the protective pad provided.

Note: Lifting the lid automatically pauses cooking.

13. Carefully turn, flip, or rotate your food.

Note: Some food does not require turning. If the lid is not removed after the turn Food indicator appears, cooking will proceed after 10 seconds.

14. Close the lid as described in step 5.

Smart Programs: Air Frying

- When there is 1 minute left, the timer counts down the remaining cooking time in seconds.
- When the Smart Program completes, the lid beeps, and the display indicates **End**.

Bake

Like a tiny oven, the Bake Smart Program can be used to create decadent brownies, puffy cakes, and much more.

You may bake with the multi-level air fryer basket or any oven-safe baking dish, such as a springform pan.

- If baking in the multi-level air fryer basket, refer to [Cleaning Before First Use—Accessories](#) for details on assembly. Line the interior with aluminum foil or parchment paper and pour in loose batter. Place the air fry basket in the inner pot.
- If using a baking dish, place the multifunctional rack on the bottom of the inner pot, then place the baking dish on the rack in the inner pot.

***Note:** Leave approximately 1"/2.5 cm of space around all sides of the baking dish to allow heat to circulate evenly.*

Unless specified in your recipe, do not cover the baking dish.

Default Temperature	Temperature Range	Suggested Use	Default Cooking Time	Cooking Time Range
365°F 185°C	180°F–400°F 82°C–204°C	Light and fluffy cakes, pastries and buns	00:30	00:01–01:00

- Insert the inner pot into the cooker base.
- Connect the power cord to a 120 V power source. The cooker goes to Standby mode and the display indicates **OFF**.
- Align the lid fins with the slots in the cooker base handles and lower the lid until a jingle sounds.

***Note:** Press the lid down slightly to ensure that the lid sensor connector contacts the base sensor connector.*

- Press **Bake** to select the Bake Smart Program.
- Use the **+ / – Temp** buttons to adjust the temperature in increments of 1°C / 5°F.
- Use the **+ / – Time** buttons to adjust the cook time.

***Note:** Adjustments to the cooking time and temperature are saved when you press **Start**.*

- Press **Start** to begin. The display reads **On** to indicate that the cooker has begun Pre-heating.

Smart Programs: Air Frying

- When the cooker reaches the target temperature, **On** changes to the cooking countdown timer.
- When there is **00:01** minute left, the timer counts down the remaining cooking time in seconds.
- When the Smart Program completes, the lid beeps, and the display indicates **End**.

Broil

Broiling involves direct top-down heating, and broiled foods benefit from being placed close to the element.

Default Temperature	Temperature Range	Suggested Use	Default Cooking Time	Cooking Time Range
400°F 204°C	Not Adjustable	Melt cheese on French onion soup or nachos	00:08	00:01-00:40

- Place food on the broil/dehydrating tray in the multi-level air fryer basket. Ensure you do not overfill the basket as it may come into contact with the air fryer lid and cause damage.
Note: Refer to [Cleaning Before First Use—Accessories](#) for details on assembly.
- Insert the air fryer basket into the inner pot.
- Insert the inner pot into the cooker base.
- Connect the power cord to a 120 V power source. The cooker goes to Standby mode and the display indicates **OFF**.
- Align the lid fins with the slots in the cooker base handles and lower the lid until a jingle sounds.
Note: Press the lid down slightly to ensure that the lid sensor connector contacts the base sensor connector.
- Press **Broil** to select the Broil Smart Program.
- Use the **+ / - Time** buttons to adjust the cook time.
Note: Adjustments to the cooking time are saved when you press Start. Temperature is not adjustable.
- Press **Start** to begin. The cooking timer begins counting down immediately.
- When there is **1** minute left, the timer counts down the remaining cooking time in seconds.
- When the Smart Program completes, the lid beeps, and the display indicates **End**.

Smart Programs: Air Frying

Dehydrate

The Dehydrate Smart Programs applies a low heat over a long period of time to safely dry out food items.

Always follow a trusted recipe when dehydrating meat.

NOTICE

Do not crowd the multi-level air fryer basket or the broil/dehydrating tray. Air must be able to circulate freely around food items.

Default Temperature	Temperature Range	Suggested Use	Default Cooking Time	Cooking Time Range
125°F 52°C	105°F-165°F 41°C-74°C	Make fruit leather, jerky, dried vegetables	07:00	01:00-72:00

1. Place food on the bottom of the multi-level air fryer basket, as well as on the broil/dehydrating tray if needed.

Note: Refer to [Cleaning Before First Use—Accessories](#) for details on assembly.

2. Insert the air fryer basket into the inner pot.
3. Insert the inner pot into the cooker base.
4. Connect the power cord to a 120 V power source. The cooker goes to Standby mode and the display indicates **OFF**.
5. Align the lid fins with the slots in the cooker base handles and lower the lid until a jingle sounds.

Note: Press the lid down slightly to ensure that the lid sensor connector contacts the base sensor connector.

6. Press **Dehydrate** to select the Dehydrate Smart Program.
7. Use the **+ / - Temp** buttons to adjust the temperature in increments of 1°C / 5°F.
8. Use the **+ / - Time** buttons to adjust the cook time in 5 minute increments.

Note: Adjustments to the cooking time and temperature are saved when you press **Start**.

9. Press **Start** to begin. The cooking timer begins counting down immediately.
10. When there is 1 minute left, the timer counts down the remaining cooking time in seconds.
11. When the Smart Program completes, the lid beeps, and the display indicates **End**.

Smart Program Overview

Smart Program	Default Time	Time Range	Default Pressure / Temperature	Pressure / Temperature Range	Lid Required
Pressure Cook	00:35	00:00-04:00	Hi (High)	Lo (Low) / Hi (High)	Pressure Cooking Lid
Sauté	00:30	00:01-00:30	Hi (High)	Lo (Low) / Hi (High)	
Slow Cook	06:00	00:30-24:00	Lo (Low)	Lo (Low) / Hi (High)	
Steam	00:30	00:00-04:00	Hi (High)	Lo (Low) / Hi (High)	
Sous Vide	03:00	00:30-99:30	133°F / 56°C	70°F-200°F / 22°C-93°C	
Air Fry	00:18	00:01-01:00	400°F / 204°C	180-400°F / 82-204°C	Air Fryer Lid
Roast	00:40	00:01-01:00	380°F / 193°C	180-400°F / 82-205°C	
Broil	00:08	00:01-00:40	400°F / 204°C	Not adjustable	
Bake	00:30	00:01-01:00	365°F / 185°C	180-400°F / 82-204°C	
Dehydrate	07:00	01:00-72:00	125°F / 52°C	105°F-165°F / 41°C-74°C	

Cooking Time Chart

Food	Quantity	Setting	Cooking Time*	Cooking Temperature*
Fries (frozen)	450 g (1 lb.)	Air Fry	18-20 minutes	400°F / 205°C
	680 g (1.5 lb.)		22-24 minutes	
Fries (fresh)	450 g (1 lb.)	Air Fry	20-22 minutes	400°F / 205°C
	680 g (1.5 lb.)		24-26 minutes	
Shrimp	300 to 400 g	Air Fry	7-10 minutes	400°F / 205°C
Quarter Chicken	350 to 450 g	Roast	37-39 minutes	400°F / 205°C
Chicken Wings	8 to 10 pieces	Air Fry / Roast	17-19 minutes	385°F / 196°C
Steak	350 to 450 g	Roast	Medium-rare: 12 minutes	400°F / 205°C
			Medium: 14 minutes	
			Medium-well: 16 minutes	
Pork Ribs	1000 to 1500 g	Step 1: Pressure Cook	15-20 minutes	Hi (High)
		Step 2: Broil	15-20 minutes	400°F / 205°C
Cauliflower	250 to 300 g	Air Fry / Roast	11-13 minutes	400°F / 205°C
Asparagus	18 to 22 pieces	Air Fry / Roast	3-5 minutes	400°F / 205°C
Cake	250 g (half box cake)	Bake	28-30 minutes	360°F / 182°C
Cupcakes	250 g	Bake	15-18 minutes	350°F / 177°C
Nachos	Any amount	Broil	5-7 minutes	400°F / 205°C

*Cooking times and temperatures are recommendations only. Always follow a trusted recipe.

For a complete list of cooking times, visit [our website](#).

Grain-to-Water Ratios

Rice & Grain	Grain : Water Ratio
White or Brown Rice	1 : 1 cup
Quinoa	1 : 3/4 cup
Oatmeal	1 : 3 cups
Risotto	1 : 2 cups - add additional wine to taste
Porridge	1 : 10 cups

Click [here](#) for a complete list of cooking timetables.

Care and Cleaning

Clean your Instant Pot Duo Crisp + Air Fryer after each use.

Always unplug the Duo Crisp and let it cool to room temperature before cleaning.

Let all surfaces dry thoroughly before use and storage.

Part	Instruction	Cleaning Method
Accessories <ul style="list-style-type: none"> • Multifunctional Rack • Condensation Collector • Protective Pad and Storage Cover • Multi-Level Air Fryer Basket • Air Fryer Basket Base • Broil/Dehydrating Tray • Condensation Collector 	<ul style="list-style-type: none"> • Wash after each use. • Never use harsh chemical detergents, powders or scouring pads on accessories. • Optionally, spray the cooking tray and/or air fryer basket with non-stick cooking spray before adding food for easier clean-up. • When machine washing, place on top rack. • Empty and rinse condensation collector after each use. • Disassemble air fryer basket before cleaning. 	Dishwasher Safe* and Hand Washable
Pressure Cooker Lid and Parts <ul style="list-style-type: none"> • Steam Release Handle • Anti-Block Shield • Sealing Ring • Float Valve • Silicone Cap 	<ul style="list-style-type: none"> • Wash after each use with hot water and mild dish soap and allow to air dry, or place in top rack of dishwasher. • Remove all parts from lid before dishwashing. • With steam release valve and anti-block shield removed, clean interior of steam release pipe to prevent clogging. • To drain water from the lid after dishwashing, grasp the lid handle and hold the lid vertically over a sink, then turn it 360°— such as turning a steering wheel. • After cleaning, store the lid upside down on the cooker base. • Store sealing ring in a well-ventilated area to decrease residual odor of flavorful meals. To eliminate odors, add 1 cup water and 1 cup white vinegar to inner pot, and run Pressure Cook for 5-10 minutes, then QR pressure. 	
Inner Pot	<ul style="list-style-type: none"> • More acute hard water staining may require a vinegar dampened sponge and some scrubbing to remove. If there is tough or burned food residue at the bottom, soak in hot water for a few hours for easy cleaning. • Wash after each use. • Ensure all exterior surfaces are dry before placing in cooker base. 	

**Some discoloration may occur after machine washing, but this will not affect the cooker's safety or performance.*

Care and Cleaning

Part	Instruction	Cleaning Method
Air Fryer Lid	<ul style="list-style-type: none"> Allow the Air Fryer Lid to cool to room temperature, then clean the heating element and surrounding area with a soft, damp cloth or sponge. Ensure it is free of food debris and/or grease splatter. Wipe the exterior clean with a soft damp cloth or sponge. Do not remove the element cover. Do not rinse or immerse cooker base in water. 	Damp Cloth Only
Power Cord	<ul style="list-style-type: none"> Use a barely damp cloth to wipe any particles off power cord. Do not rinse or immerse power cord in water. 	
Cooker Base	<ul style="list-style-type: none"> Wipe the inside of the outer pot as well as the condensation rim with a barely damp cloth, and allow to air dry. Clean cooker base and control panel with a soft, barely damp cloth or sponge. Do not rinse or immerse cooker base in water. 	

Note: To remove baked-on grease and food residue from accessories and the Air Fryer Lid, spray with a mixture of baking soda and vinegar and wipe clean with damp cloth. For stubborn stains, allow the mixture to sit on the affected area for several minutes before scrubbing clean.

⚠ WARNING				
Do not immerse the appliance in water or any other liquid. Do not rinse the appliance under a tap.	Ensure the heating element remains dry at all times.	Do not submerge the power cord at any time. Do not wet the prongs of the power cord.	Without proper cleaning, food and grease splatter may build up around the heating element, leading to the risk of smoke, fire, and personal injury.	If you smell smoke, press Cancel and unplug the appliance. Once cool, remove food splatter or grease with a soft cloth and mild detergent.

Troubleshooting

[Register your product today.](#)

Contact Customer Care:

1-800-828-7280

support@instantpot.com

instantpot.com/#Chat

Problem	Possible Reason	Solution
Air fryer lid is in place but will not turn on	The connection between the air fryer lid and pressure cooker base is loose or broken.	Ensure the Air Fryer Lid is seated correctly on the pressure cooker base.
	Bad power connection or no power.	Inspect the power cord on the pressure cooker base to ensure a good connection. Ensure the power cord is pushed firmly into the cooker base.
	Electrical fuse has blown.	Contact Customer Care .
	Microswitch is dirty grease or damaged.	Contact Customer Care .
Black smoke is coming from the air fryer lid	Using an oil with a low smoke point.	Cancel the Smart Program, unplug the cooker and allow it to cool to room temperature. Choose a neutral oil with a high smoke point, such as Canola, Avocado, Soybean, Safflower, or Rice Bran.
	Food residue on the bottom of the inner pot or around the element on the air fryer lid.	Cancel the Smart Program, unplug the cooker and allow it to cool to room temperature. Remove all accessories from the inner pot and clean the inner pot, air fryer lid, and all accessories thoroughly.
	Appliance malfunction.	Contact Customer Care .
White Smoke is coming from the air fryer lid	Cooking foods with a high fat content, such as bacon, sausage, and hamburger.	Avoid air frying foods with a high fat content.
		Check the inner pot for excess oil and/or fat and carefully remove as needed before air frying.
	Food is moist.	As water in the food is vaporized it turns to steam and escapes the cooker. Pat dry moist food ingredients before air frying.
	Seasoning on food has blown into element	Be mindful when seasoning food. Spray vegetables and meats before adding seasoning so they adhere to the ingredients.

Troubleshooting

Problem	Possible Reason	Solution
Difficulty closing pressure cooking lid	Sealing ring not properly installed	Reposition sealing ring, ensure it is snug behind sealing ring rack.
	Float valve in the popped-up position	Gently press the float valve downward with a long utensil.
	Contents in cooker are still hot	Press quick release button down until it clicks into Vent position, then lower lid onto cooker base slowly, allowing heat to dissipate.
Difficulty opening the pressure cooking lid	Pressure inside the cooker	Release pressure according to recipe; only open lid after float valve has dropped down.
	Float valve stuck at the popped-up position due to food debris or residue	Ensure steam is completely released by quick releasing pressure, then press float valve gently with a long utensil. Open lid cautiously and thoroughly clean float valve, surrounding area, and lid before next use.
	⚠ WARNING Contents may be under pressure; to avoid scalding injury, do not attempt to force lid open.	
Inner pot is stuck to pressure cooking lid when cooker is opened	Cooling of inner pot may create suction, causing inner pot to adhere to the lid.	To release the vacuum, press quick release button down until it clicks into Vent position.
Steam leaks from side of lid	No sealing ring in lid.	Install sealing ring.
	Sealing ring damaged or not properly installed.	Replace sealing ring.
	Food debris attached to sealing ring.	Remove sealing ring and clean thoroughly.
	Lid not closed properly.	Open, then close lid.
	Sealing ring rack is warped or off-centre.	Remove sealing ring from lid, check sealing ring rack for bends or warps. Contact Customer Care .
	Inner pot rim may be misshapen.	Check for deformation and contact Customer Care .

Troubleshooting

Problem	Possible Reason	Solution
Float valve does not rise	Food debris on float valve or float valve silicone cap.	Remove float valve from lid and clean thoroughly. Perform Initial Test Run to check for function. Record findings and contact Customer Care .
	Too little liquid in the inner pot.	Check for scorching on bottom of inner pot. Add thin cooking liquid according to size: 6 Quart - 1.5 cups (12 oz / 375 mL) 8 Quart - 2 cups (16 oz / 500 mL)
	Float valve silicone cap damaged or missing.	Install silicone cap or replace float valve entirely.
	Float valve obstructed by lid-locking mechanism	Tap float valve with a long utensil. If the float valve does not drop, press Cancel and contact Customer Care .
	No heat in the inner pot	Check for scorching on bottom of inner pot. Add thin cooking liquid according to size: 6 Quart - 1.5 cups (12 oz / 375 mL) 8 Quart - 2 cups (16 oz / 500 mL)
	Inner pot base may be damaged	Perform Initial Test Run to check for function and record findings. Contact Customer Care .
Minor steam leaking/hissing from steam release valve during cook cycle	Quick release button not in Seal position	Flick quick release button to ensure it is in the Seal position.
	Cooker is regulating excess pressure	This is normal. No action required.
Steam gushes from steam release valve when quick release button is in Seal position	Not enough liquid in the inner pot	Add thin cooking liquid according to size: 6 Quart - 1.5 cups (12 oz / 375 mL) 8 Quart - 2 cups (16 oz / 500 mL)
	Pressure sensor control failure	Contact Customer Care .
	Steam release valve not seated properly	Flick quick release button to ensure it is in the Seal position.
Display remains blank after connecting the power cord	Bad power connection or no power	Inspect power cord for damage. If damage is noticed, contact Customer Care . Check outlet to ensure it is powered.
	Cooker's electrical fuse has blown	Contact Customer Care .
Occasional clicking or light cracking sound	The sound of power switching and expanding pressure board when changing temperatures	This is normal; no action needed.
	Bottom of the inner pot is wet	Wipe exterior surfaces of inner pot. Ensure heating element is dry before inserting inner pot into cooker base.

Troubleshooting

	Error Code	Meaning of error code	
Error code appears on display and cooker beeps continuously	C1 C2 C6 C6H C6L	Faulty sensor	Contact Customer Care .
	C5	Temperature is too high because inner pot is not placed in the cooker base	Press Cancel and wait for heating element to cool; ensure there are no foreign objects in cooker base; insert or reposition inner pot in cooker base and re-enter commands.
		Temperature is too high because there is no water in inner pot	Add thin cooking liquid according to size, then reintroduce food: 6 Quart - 1.5 cups (12 oz / 375 mL) 8 Quart - 2 cups (16 oz / 500 mL)
	C7 or NoPr	Not enough liquid	Add thin cooking liquid according to size: 6 Quart - 1.5 cups (12 oz / 375 mL) 8 Quart - 2 cups (16 oz / 500 mL) Add more liquid as required.
		Quick release button is in the Vent position	Flick quick release button to ensure it is in the Seal position.
	C9	Sensor connectors on Air Fryer Lid and cooker base are not making full contact.	Press the lid down slightly to ensure that the female lid sensor connector contacts the male base sensor connector.
	Lid	Lid is not in the correct position for the selected program	Open and close the lid. Do not use a lid when using Sauté .
	Pot	Inner pot is missing from the cooker base	Insert the inner pot into the cooker base and try again. If the error code appears while the inner pot is in the cooker base, contact Customer Care .
	Burn / Food burn	High temperature detected at bottom of inner pot; cooker automatically reduces temperature to avoid overheating	Starch deposits at the bottom of the inner pot may have blocked heat dissipation. Turn the cooker off, release pressure according to the recipe, and inspect the bottom of the inner pot.
PrSE	Pressure has accumulated during a non-pressure cooking program	Press quick release button down until it clicks into Vent position.	

Any other servicing should be performed by an authorized service representative.

Warranty

Limited Warranty

This Limited Warranty is effective for one year from the date of original consumer purchase. Proof of original purchase date and, if requested by an authorized representative of Instant Brands Inc. ("Instant Brands"), return of your appliance, is required to obtain service under this Limited Warranty. Provided that this appliance is operated and maintained in accordance with written instructions attached to or furnished with the appliance, Instant Brands will, in its sole and exclusive discretion, either: (i) repair defects in materials or workmanship; or (ii) replace the appliance. In the event that your appliance is replaced, the Limited Warranty on the replacement appliance will expire 12 months from the date of original consumer purchase.

This Limited Warranty extends only to the original purchaser and use of the appliance in the United States of America and Canada. This warranty does not cover units that are used outside of the United States of America and Canada.

Any modification or attempted modification to your appliance may interfere with the safe operation of the appliance and will void this Limited Warranty. This Limited Warranty does not apply in respect of any appliance or any part thereof that has been altered or modified unless such alterations or modifications were expressly authorized by an Instant Brands representative.

Limitation and Exclusions

The liability of Instant Brands, if any, for any allegedly defective appliance or part shall in no circumstances exceed the purchase price of a comparable replacement appliance.

This Limited Warranty does not cover:

1. Damage resulting from accident, alteration, misuse, abuse, neglect, unreasonable use, use contrary to the operating instructions, normal wear and tear, commercial use, improper assembly, disassembly, failure to provide reasonable and necessary maintenance, fire, flood, acts of God or repair by anyone unless directed by an Instant Brands Representative;
2. Repairs where your appliance is used for other than normal, personal use or when it is used in a manner that is contrary to published user or operator instructions; or
3. Use of unauthorized parts and accessories, or repairs to parts and systems resulting from unauthorized repairs or modifications made to this appliance.

The cost of repair or replacement under these excluded circumstances shall be paid by you.

Warranty

Disclaimer of Implied Warranties

EXCEPT AS EXPRESSLY PROVIDED HEREIN AND TO THE EXTENT PERMITTED BY LAW, INSTANT BRANDS MAKES NO WARRANTIES, CONDITIONS OR REPRESENTATIONS, EXPRESS OR IMPLIED, BY STATUTE, USAGE, CUSTOM OF TRADE OR OTHERWISE WITH RESPECT TO THE APPLIANCES OR PARTS COVERED BY THIS WARRANTY, INCLUDING BUT NOT LIMITED TO, WARRANTIES, CONDITIONS, OR REPRESENTATIONS OF WORKMANSHIP, MERCHANTABILITY, MERCHANTABLE QUALITY, FITNESS FOR A PARTICULAR PURPOSE OR DURABILITY.

Some states or provinces do not allow for the exclusion of implied warranties of merchantability or fitness, so this limitation may not apply to you. In these states and provinces, you have only the implied warranties that are expressly required to be provided in accordance with applicable law.

Limitation of Remedies;

Exclusion of Incidental and Consequential Damage

YOUR SOLE AND EXCLUSIVE REMEDY UNDER THIS LIMITED WARRANTY SHALL BE APPLIANCE REPAIR OR REPLACEMENT AS PROVIDED HEREIN. INSTANT BRANDS SHALL NOT BE LIABLE FOR INDIRECT, INCIDENTAL OR CONSEQUENTIAL DAMAGES ARISING OUT OF OR IN CONNECTION WITH THE USE OR PERFORMANCE OF THE APPLIANCE OR DAMAGES WITH RESPECT TO ANY ECONOMIC LOSS, PERSONAL INJURY, LOSS OF PROPERTY, LOSS OF REVENUES OR PROFITS, LOSS OF ENJOYMENT OR USE, COSTS OF REMOVAL, INSTALLATION OR OTHER INDIRECT, INCIDENTAL OR CONSEQUENTIAL DAMAGES OF ANY NATURE OR KIND.

Warranty Registration

Please visit www.instantpot.com/support/register to register your new Instant Brands™ appliance and validate your warranty within thirty (30) days of purchase. You will be asked to provide the store name, date of purchase, model number (found on the back of your appliance) and serial number (found on the bottom of your appliance) along with your name and email address. The registration will enable us to keep you up to date with product developments, recipes and contact you in the unlikely event of a product safety notification. By registering, you acknowledge that you have read and understand the instructions for use, and warnings set forth in the accompanying instructions.

Warranty Service

To obtain service under this warranty, please contact our Customer Service Department by phone at 1-800-828-7280 or by email to support@instantpot.com. You can also create a support ticket online at www.instantpot.com/support. If we are unable to resolve the problem, you may be asked to send your appliance to the Service Department for quality inspection. Instant Brands is not responsible for shipping costs related to warranty service, save and except for shipping costs associated with the return of your appliance from Canada or within the 48 contiguous states and the District of Columbia of the United States of America, as provided herein. When returning your appliance, please include your name, mailing address, email address, phone number, and proof of the original purchase date as well as a description of the problem you are encountering with the appliance.



Instant Pot®

Instant Brands Inc.
11-300 Earl Grey Dr., Suite 383
Ottawa, Ontario
K2T 1C1
Canada

Register your product today
instantpot.com/support/register

Contact Information

[1-800-828-7280](tel:1-800-828-7280)

support@instantpot.com

instantpot.com/#chat

instantpot.com

store.instantpot.com