

get started

INSTANT POT® **DUO™ CRISP**
WITH ULTIMATE LID
USER MANUAL

Instant®

Welcome

to your new Duo Crisp with Ultimate Lid!

This Instant® Duo Crisp with Ultimate Lid is designed to pressure cook and air fry using a single lid. It'll help you cook healthy, delicious meals more easily and in less time. We hope you fall in love with your Instant Duo Crisp, and enjoy it in your kitchen for years to come!

Learn all about your Duo Crisp!



⚠ WARNING

Before using your new Duo Crisp, read all instructions, including the Safety and Warranty document. Failure to follow the safeguards and instructions may result in personal injury and/or property damage.

CONTENTS

| | |
|-----------------------------|----|
| What's in the box | 10 |
| Using your Duo Crisp | 11 |
| Changing Duo Crisp settings | 12 |
| Using the Ultimate Lid | 14 |
| Initial set up | 18 |
| Pressure Cook + Steam | 20 |
| Sauté | 23 |
| Slow Cook | 25 |
| Sous Vide | 27 |
| Yogurt | 29 |
| Air Fry | 31 |
| Bake + Roast | 33 |
| Broil | 35 |
| Dehydrate + Proofing | 36 |
| Keep Warm | 38 |
| Cleaning | 39 |
| Trouble shooting | 40 |
| Error codes | 42 |
| Learn more | 43 |
| Warranty | 44 |

INSTANT POT®

DUO™ CRISP WITH ULTIMATE LID

Safety Instructions

At Instant, we want you to feel comfortable using our products. This Instant Pot Duo Crisp was designed with you and your safety in mind.

Read all instructions before using and only use this appliance as directed. Failure to follow these Important Safeguards may result in personal injury and/or property damage and will void your warranty.

When using electrical appliances, basic safety precautions should always be followed to reduce the risk of fire, electric shock, personal injury and/or property damage



IMPORTANT SAFEGUARDS



⚠ WARNING

READ ALL INSTRUCTIONS

Placement

DO place the appliance on a countertop only. Always operate the appliance on a stable, non-combustible, level surface.

DO make sure all parts are dry and free of food debris before placing the cooking pot on the cooker base.

DO NOT place the appliance on or close to a hot gas or electric burner, or a heated oven.

DO NOT use the appliance near water or flame.

DO NOT use outdoors. Keep out of direct sunlight.

DO NOT place on anything that may block the vents on the bottom of the appliance.

General Use

The removable inner cooking pot is extremely hot during use, and can be extremely heavy when full of ingredients.

DO use oven mitts when handling the inner cooking pot and removing accessories.

DO place hot accessories on a heat-resistant surface or cooking plate.

DO use care when lifting the cooking pot from the cooker base to avoid burn injury.

DO use extreme caution when the cooking pot contains hot food, hot oil or other hot liquids.

⚠ WARNING

DO use only the Instant Pot lid that came with this cooker base. Using any other pressure cooker or air fryer lids may cause personal injury and/or property damage.

DO NOT use the appliance without the removable inner cooking pot installed.

DO NOT touch the metal portion of the lid, the appliance's hot surfaces, or any accessories during or immediately after cooking because they will be hot. Only use the side handles for carrying or moving.

DO NOT use this appliance for deep frying with oil.

DO NOT move the appliance while it is in use and use extreme caution when disposing of hot grease.

DO NOT allow children or persons with reduced physical, sensory or mental capabilities to operate this appliance. Close supervision is necessary when any appliance is used by or near children and persons with reduced physical, sensory or mental capabilities. Children should not play with this appliance.

DO NOT use the appliance for anything other than household use. It is not intended for commercial use.

DO NOT leave the appliance unattended while in use.

Pressure Cooking

This appliance cooks under pressure. Allow the appliance to depressurize naturally or release all excess pressure before opening. Inappropriate use may result in burns, personal injury and/or property damage.

DO make sure the appliance is properly closed before operating.

DO check that the steam release valve is installed.

DO use the pressure cooking lid when pressure cooking. *For instructions on how to use the lid, see the User Manual or Getting Started Guide.*

⚠ WARNING

DO turn the appliance off if steam escapes from the steam release valve and/or float valve in a steady stream for longer than 3 minutes. If steam escapes from the sides of the lid, turn the appliance off. Once steam stops, pressure is released, and the cooker has cooled carefully make sure the sealing ring is properly installed.

DO check the steam release valve, steam release pipe, anti-block shield and float valve for clogging before use. *For instructions on how to clean these parts, see the User Manual.*

DO NOT attempt to force the lid off the Instant Pot cooker base.

DO NOT move the appliance when it is under pressure.

DO NOT cover or obstruct the steam release valve and/or float valve with cloth or other objects.

DO NOT attempt to open the appliance until it has depressurized, and all internal pressure has been released. Attempting to open the appliance while it is still pressurized may lead to sudden release of hot contents and may cause burns, personal injury, and/or property damage.

DO NOT place your face, hands or exposed skin over the steam release valve or float valve when the appliance is in operation or has residual pressure, and do not lean over the appliance when removing the lid.

Overfill During Pressure Cooking

Overfilling may cause a risk of clogging the steam release pipe and developing excess pressure.

DO NOT fill the inner cooking pot over the line labeled 'PC MAX – 2/3'.

DO NOT fill the inner cooking pot over the line labeled '– 1/2' when cooking foods that expand during cooking such as rice, dried beans or dried vegetables.

⚠ WARNING

DO be aware that certain foods, such as applesauce, cranberries, pearl barley, oatmeal or other cereals, split peas, noodles, macaroni, rhubarb, or spaghetti can foam, froth, sputter, and clog the pressure release device (steam vent).

DO NOT fill the cooking pot higher than the "1/2" line when cooking these foods.

DO NOT place oversized foods into the inner cooking pot as they may cause risk of fire, personal injury and/or property damage.

DO check that sealing ring is properly installed.

Air Frying

When the unit is air frying, hot air is released through the air vents. Keep your hands and face away from the air vents and take extreme caution when removing hot accessories from the appliance. Failure to do so may result in personal injury or property damage.

DO use the included inner cooking pot when air frying.

DO use the lid when air frying. *For instructions on how to use the lid, see the User Manual or Getting Started Guide.*

DO NOT place unprotected hands inside the appliance until it has cooled to room temperature.

DO NOT use a ceramic-coated or stoneware inner pot (such as CorningWare® stoneware) for air frying.

DO NOT block the vents on the bottom of the cooker base or on the lid. Leave at least 5" / 13 cm of space around the lid when in use.

DO NOT place the appliance on a hot stove.

DO NOT operate the appliance on or near combustible materials such as tablecloths and curtains.

DO NOT cover the air vents while air frying. Doing so will prevent even cooking and may cause damage to the appliance.

⚠ WARNING

DO NOT place the lid directly on countertop; use the protective pad provided.

Should the unit emit black smoke when air frying, press **Cancel** and unplug the appliance immediately. Wait for smoking to stop before removing the lid, then clean thoroughly.

Overfill During Air Frying

DO NOT overfill the air fryer basket when air frying. Only fill air fryer basket as high as the basket handles, and no higher.

DO NOT allow food to contact the heating element.

Accessories

DO use only accessories or attachments authorized by Instant Brands. The use of parts, accessories or attachments not recommended by the manufacturer may cause a risk of fire, personal injury and/or property damage.

DO use only an authorized stainless-steel Instant Pot inner cooking pot to reduce the risk of pressure leakage.

DO only replace the sealing ring with an authorized Instant Pot sealing ring to prevent personal injury and damage to the appliance.

DO NOT use the included accessories in a microwave, toaster oven, convection or conventional oven, or on a ceramic cooktop, electric coil, gas range or outdoor grill.

Care and Storage

DO let the appliance cool to room temperature before cleaning or storage.

DO NOT store any materials in the cooker base when not in use.

DO NOT place any combustible materials in the cooker base, such as paper, cardboard, plastic, Styrofoam or wood.

⚠ WARNING

Power Cord

A short power-supply cord is used to reduce the risk resulting from it being grabbed by children, becoming entangled in, or tripping over a longer cord.

WARNING: Spilled food can cause serious burns. Keep appliance and cord away from children.

Never drape cord over edge of counter, never use outlet below counter, and never use with an extension cord.

DO NOT let the power cord touch hot surfaces or open flame, including the stovetop.

DO NOT use with power converters or adapters, timer switches or separate remote-control systems.

This appliance has a 3-prong grounding plug. To reduce the risk of electric shock:

ONLY plug the power cord into a grounded electrical outlet.

DO NOT remove ground.

Electrical Warning

The cooker base contains electrical components that are an electrical shock hazard. Failure to follow these instructions may result in electric shock.

To protect against electrical shock:

To disconnect, select **Cancel**, then remove plug from power source. Always unplug when not in use, as well as before adding or removing parts or accessories, and before cleaning. To unplug, grasp the plug and pull from the outlet. Never pull from the power cord.

DO regularly inspect the appliance and power cord. **DO NOT** operate the appliance if the power cord or plug is damaged, or after the appliance malfunctions or is dropped or damaged in any manner. For assistance, contact Customer Care by email at **support@instanthome.com**.

⚠ WARNING

DO NOT attempt to repair, replace or modify components of the appliance, as this may cause electric shock, fire or fire, personal injury and/or property damage, and will void the warranty.

DO NOT tamper with any of the safety mechanisms, as this may result in personal injury or property damage.

DO NOT put liquid or food of any kind into cooker base without the inner cooking pot.

DO NOT immerse power cord, plug or the appliance in water or other liquid.

DO NOT use the appliance in electrical systems other than 120 V ~ 60 Hz for North America.

SAVE THESE INSTRUCTIONS

WHAT'S IN THE BOX

Duo Crisp

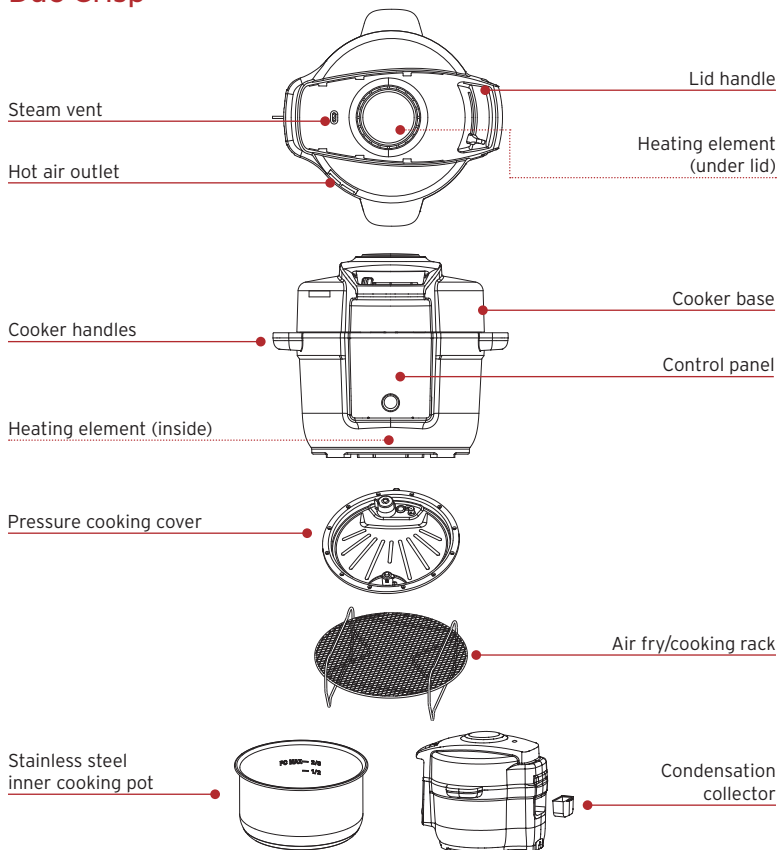

Illustrations are for reference only and may differ from the actual product.

Remember to recycle!

We designed this packaging with sustainability in mind. Please recycle everything that can be recycled where you live. Be sure to keep this Guide, along with the Safety and Warranty insert for reference.

USING YOUR DUO CRISP

Control panel

We've designed the control panel to be simple to use and easy to read.

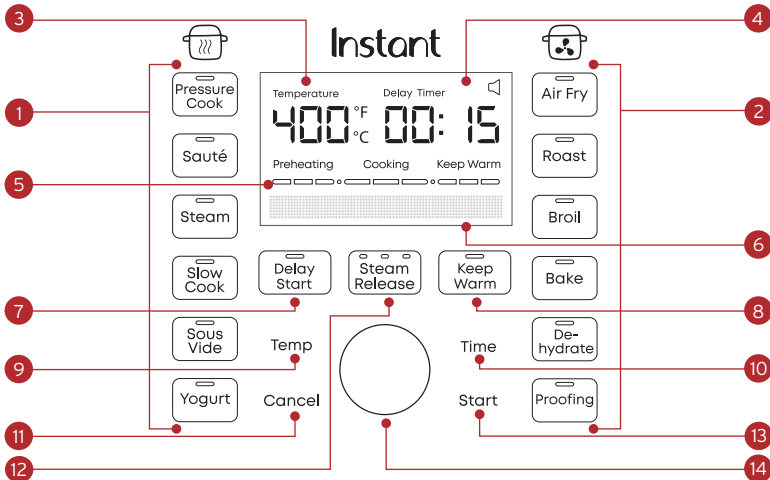

1. Pressure Cooking smart programs
 - Light shows the active smart program
2. Air Frying smart programs
 - Light shows the active smart program
3. Temperature Display
 - Choose Fahrenheit or Celsius
4. Time Display
 - Cook time countdown
 - Keep Warm count
5. Cooking Progress Bar
6. Message Bar
 - Displays status messages
7. Delay Start
 - Can also serve as Kitchen Timer
8. Keep Warm
 - On or Off
9. Temperature
10. Time
11. Cancel
12. Steam Release Control Button
 - Lights show type of steam release selected
13. Start
14. Control Dial
 - Adjust time and temperature

Cooking Progress Bar

1. **Preheating:** cooker is heating to the set temperature. Display shows cooking time.
2. **Cooking:** cooker has started the smart program. Display counts down cooking time.
3. **Keep Warm:** turns on automatically after cooking stops. When done, display shows **End**.

CHANGING DUO CRISP SETTINGS

Turning sound On/Off

You can choose to have audible cooking alerts on or off.

- When in Ready mode, press and hold the **Time** and **Temperature** buttons for 5 seconds until the display shows **Sound On** or **Sound Off**.

Audible safety alerts (beeps) cannot be turned off.

Choosing temperature scale

You can choose to show cooking temperature in either Fahrenheit or Celsius.

- When in Standby mode, press and hold the **Temp** button for 5 seconds until the display shows **Temp Unit F** or **Temp Unit C**.

Delay the start of cooking

You can use Delay Start to delay cooking for a minimum of 10 minutes or a maximum of 24 hours.

4. Select a smart program, adjust the settings as you want, then press **Delay Start**.
5. When the time flashes, use the **Control Dial** to adjust the delay time.
6. Press **Start** and the timer counts down.
7. When Delay Start ends, the smart program begins, and the display shows cooking time.
8. Delay Start is not available with the **Air Fry, Sauté, Yogurt, Sous Vide, Roast, Broil, Bake, Dehydrate, Proofing** or **Keep Warm** smart programs.

Set a timer

You can set a cooking timer for a minimum of 1 minute or a maximum of 1 hour.

1. When in Ready mode, press **Delay Start**.
2. When the time flashes, use the **Control Dial** to adjust the delay time.
3. Press **Start** and the timer counts down.
4. When the timer ends, the display shows **Ready**.

Reset Smart Programs to original settings

Reset smart programs

- While in Ready mode, press and hold one smart program button for over 3 seconds until the smart program button blinks twice.
The smart program's settings are restored to the factory default setting.
- While in Cooking mode, press and hold the currently-used smart program button for over 3 seconds until the smart program button blinks twice.
The smart program's settings are restored to the factory default setting.

Reset all settings

- While in Ready mode, press and hold the Control Dial for over 3 seconds until the smart program buttons blink 3 times and the display shows **Ready**.
All settings are restored to the factory default setting.

USING THE ULTIMATE LID

You'll use the Ultimate Lid for both pressure cooking and air frying, as well as other types of cooking. Always use the lid that came with this Instant Pot Duo Crisp cooker base.

⚠ WARNING

Do not open the lid until all pressure is released and the the message says "Ok to open lid." Opening the lid before pressure is released, may result in burns, personal injury and/or property damage. Do not lean over steam vent. Hot steam may release and result in burns or personal injury.

Open the Lid

1. After pressure cooking, be sure to release the steam before opening. See How to Release Steam on page 9.
2. Turn the Lid Lock Switch to the **Unlock** position.
3. Use the lid handle to raise the lid from the cooker base.

Close and lock the Lid

For pressure cooking, the lid must be securely locked into place to prevent steam from escaping.

1. Use the lid handle to lower the lid onto the cooker base, and press the lid down.
2. For pressure cooking turn the Lid Lock Switch to the **Lock** position.

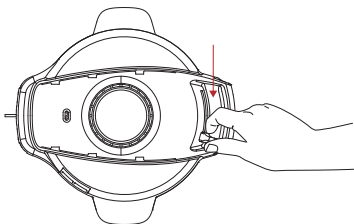
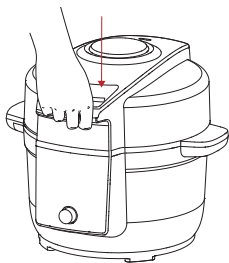

How to use the Pressure Cover

For pressure cooking and other smart programs that use the pressure cooking functions of the Ultimate Lid, you'll need to install the Pressure Cooking Inner Cover.

Install the Pressure Cooking Cover

1. Insert the Pressure Cooking Cover into the slot on the underside of the Ultimate Lid, bottom first.

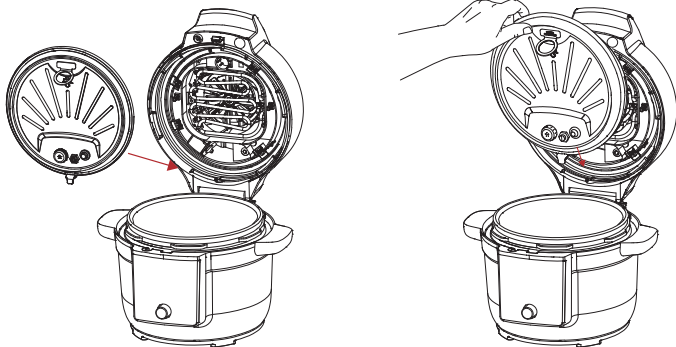

2. Push the Pressure Cooking Cover fully into place. When the Pressure Cooking Cover is in place, you will hear a locking sound.

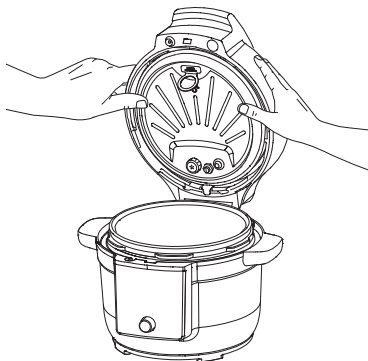

Remove the Pressure Cooking Cover

1. Open the Ultimate Lid, and then grasp the Inner Cover holder loop.
2. *Be sure to hold the Pressure Cooking Cover holder loop with a kitchen cloth or protective gear since it may still be hot.*

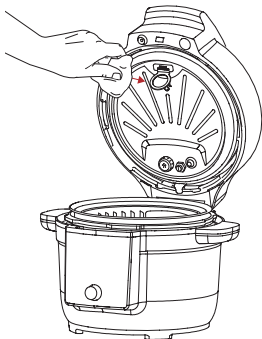

3. Press the red button on top of the lid, and the Inner Cover will release.

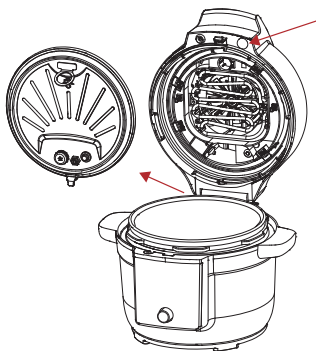

How to release steam

Your Duo Crisp can release steam in 3 different ways. Use the one that best fits the type of food you're cooking.

| Choose | Natural Release | Pulse Release | Quick Release |
|---------|---|---|---|
| How? | Releases steam gradually over time (up to 40 minutes or more) after cooking stops | Releases timed bursts of steam in quick puffs after cooking stops | Quickly releases steam after you press the steam release button |
| Use for | Foods that can simmer, like stews, chili, pasta, oatmeal, beans and grains | Foods like rice and grains | Foods that tend to overcook, like vegetables and seafood |

How to release steam

1. Press the Steam release on the Front Control Panel to toggle between Natural Release, Pulse Release and Quick Release.

You can change the steam release type any time: before, during, or after cooking.

2. When all steam is released the display shows **OK to open lid**.
3. After steam release, you can use the lid handle to open the lid.

Hot steam releases from the steam vent; do not place your hands or face near the vent when steam is releasing.

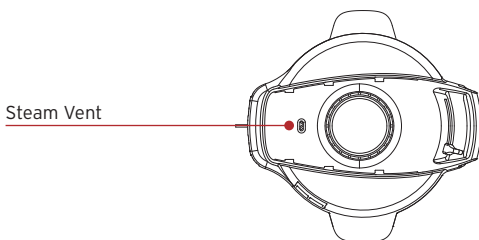

INITIAL SET UP

Clean before use

1. Wash the Inner Cooking Pot with hot water and soap. Rinse and use a soft cloth to dry the outside. Or you can wash the Inner Cooking Pot in the dishwasher
2. Wipe the heating element inside the cooker base and the inside of the Ultimate Lid with a soft cloth to ensure there are no stray packaging particles.

Using the condensation collector

The condensation collector sits at the back of the cooker base and accumulates overflow moisture from the condensation rim. It should be installed before cooking, then emptied and rinsed out after each use.

Remove the condensation collector

- Pull the condensation collector away from the cooker base; do not pull down.

Note the tabs on the cooker base and the grooves on the condensation collector.

Install the condensation collector

- Align the grooves on the condensation collector with the tabs on the back of the cooker base and slide the condensation collector into place.

Using the Air Fry/Cooking Rack

With a reversible design that has two sides with two different handle heights, the Air Fry/Cooking Rack is a versatile tool that you can use for most cooking programs.

- Tall handle side up: air frying, roasting, baking, pressure cooking and steaming
- Short handle side up: broiling and dehydrating

For smaller foods, that could fall out of the rack area during cooking, consider using a baking dish that holds the food inside.

Test run

Before using your new Duo Crisp for the first time, you must perform a pressure cooking test run to ensure everything is working correctly.

To perform a test run:

1. Follow the instructions for pressure cooking on page 20.
2. Fill the cooking pot with water to the first fill line, but do not add food.
3. Select **Pressure Cook**
4. Set the cooking time to 5 minutes.
5. Select **Quick Steam Release** under the steam button.
6. Press **Start**.
7. When done, appliance will release steam.
8. After steam is released, message bar will show **Ok to open lid**.
9. Wash and dry the inner cooking pot.

Now you're ready to cook a meal in your Duo Crisp!

PRESSURE COOK + STEAM

Both programs use pressurized steam to quickly and evenly cook foods. Use Pressure Cook for most pressure cooking recipes and use Steam as you would a regular stovetop steamer, boiling liquid to cook food with hot steam.

⚠ WARNING

MUST USE INNER POT

Inner cooking pot must always be used. To prevent personal injury, do not place food or liquid into cooker base.

DO NOT OVERFILL

Over-filling the Inner Cooking Pot may lead to personal injury or property damage.

Do not fill the Inner Cooking Pot higher than the PC Max - 2/3 line as indicated in the Inner Cooking Pot.

Do not fill the Inner Cooking Pot higher than the -1/2 line when cooking foods that expand, such as uncooked beans, applesauce, oatmeal, barley, and noodles.

DO NOT REMOVE LID WHEN PRESSURE COOKING

Do not open lid when pressure cooking. Removing the lid before pressure is released may result in burns, personal injury, and/or property damage.

Using liquid for pressure cooking

Pressure cooking requires liquid in the Inner Cooking Pot to produce the steam needed. For this Duo Crisp, here are the minimum amounts you'll need:

| Cooking Pot Size | Minimum Liquid for Pressure Cooking* |
|------------------------|--------------------------------------|
| 6.5 Quarts/ 6.2 Litres | 2 cups (12 oz / 500 mL) |

**Unless otherwise specified in recipe.*

Pressure cooking liquids should be water-based, such as broth, stock, soup or juice. If using canned, condensed, or cream-based soup, add water as directed above.

Program settings

Choose from these settings for each smart program:

| Smart Program | Temperature | Default Cook Time | Min. Cook Time | Max. Cook Time |
|---------------|-------------------|--------------------|-------------------|-----------------|
| Pressure Cook | Automatically set | 10 minutes (00:10) | 0 minutes (00:00) | 4 hours (04:00) |
| Steam | Automatically set | 10 minutes (00:10) | 0 minutes (00:00) | 1 hours (01:00) |

How to pressure cook or steam

Prep

Cut, chop, season or marinate your ingredients according to your recipe.

Preheat

1. Place the Inner Cooking Pot into the cooker base.
2. Add ingredients to the Inner Cooking Pot.
3. Make sure the Pressure Cooking Cover is installed in the Ultimate Lid.
4. Close the lid on the cooker base and lock it.
See 'Close and lock the lid' for full details.
5. Press **Pressure Cook** or **Steam**. The indicator light blinks.
6. The default or last-used cooking time displays. To change it, press **Time** and turn the **Control Dial** to change it, then press **Control Dial** to select it.

7. For the Pressure Cook smart program, Keep Warm is **On** by default. If you want to turn it off, press **Keep Warm**.
8. The default or last-used steam release type is displayed. To change it, press the **Steam Release** button as needed to toggle through the options.
See 'How to release steam' for full details.
9. Press **Start**. The Progress Bar shows **Preheating** and the Duo Crisp starts heating. The display shows Preheating.

It can take 10-15 minutes to preheat for cooking. Preheating time can be longer than 15 minutes for 2/3 max. Frozen foods increase the preheating time. The cooking time you choose will be the new setting the next time you use that smart program.

Cook

1. When the pressure is ready, the Duo Crisp starts pressure cooking. The unit displays **Cooking** and the cooking timer starts counting down.
2. When the timer reaches 00:00, cooking stops.
3. When the display shows **Ok to Open Lid**, you can open the lid.
4. Press **Cancel** if you want to finish cooking before the timer stops.

Keep Warm

When the Pressure Cook smart program completes and Keep Warm is turned on, the timer begins counting from 00:00 up to 10 hours (10:00). If Keep Warm is turned off, the display shows End.

SAUTÉ

Use Sauté in place of a frying or saucepan. Sautéing can deepen the flavors of your food, or can simmer, thicken or reduce sauces.

Choose from these settings to sauté:

| Default Temp. | Min. Temp. | Max. Temp. | Default Cook Time | Min. Cook Time | Max. Cook Time |
|---------------|------------|------------|--------------------|------------------|----------------|
| Level 1 | Level 1 | Level 6 | 30 minutes (00:30) | 1 minute (00:01) | 1 hour (01:00) |

How to sauté

Prep

Cut, chop, season or marinate your ingredients according to your recipe.

Preheat

1. Place the Inner Cooking Pot into the cooker base.
2. Keep the lid open during the entire Sauté cooking process.
3. Press **Sauté**. The indicator light blinks.
4. The default or last-used cooking time displays. To change it, press **Time** and turn the **Control Dial** to change it, then press **Control Dial** to select it.
5. The default or last-used cooking temperature displays. To change it, press **Temp** and turn the **Control Dial** to change it, then press **Control Dial** to select it.
6. Press **Start**. The Progress Bar shows **Preheating** and the Duo Crisp starts heating. The display shows **Preheating**.

Cook

1. When display shows **Add Food**, add ingredients.
2. The unit displays **Cooking**.
3. When timer ends, display shows **End**.
4. Press **Cancel** if you want to finish cooking before the timer stops.

Deglazing

Deglazing is the process of adding a liquid to a hot pan, releasing all of the delicious, caramelized pieces stuck to the bottom.

1. Remove food from inner pot.
2. Add water, broth, or wine.
3. Use wooden spoon or silicone spatula to loosen food stuck to bottom of the Inner Cooking Pot.

Sautéing before Pressure or Slow Cooking

Quite often, you'll want to sauté foods to brown them before further cooking them.

1. Sauté ingredients.
2. Press **Cancel**.
*You can deglaze the Inner Cooking Pot now before switching to **Pressure Cook** or **Slow Cook** (see **Deglazing**).*
3. Select the smart program you want to use to cook.

SLOW COOK

Slow Cook lets you make your favorite simmering and stewing recipes. This program does not use pressure to cook food.

Choose from these settings for slow cooking:

| Default Temp. | Min. Temp. | Max. Temp. | Default Cook Time | Min. Cook Time | Max. Cook Time |
|---------------|------------|------------|-------------------|--------------------|------------------|
| High | Low | High | 4 hours (04:00) | 30 minutes (00:30) | 24 hours (24:00) |

How to slow cook

Prep

Cut, chop, season or marinate your ingredients according to your recipe.

Preheat

1. Place the Inner Cooking Pot into the cooker base.
2. Add ingredients to the Inner Cooking Pot.
3. Make sure the Pressure Cooking Cover is installed in the Ultimate Lid.
4. Close the lid on the cooker base and lock it.
See 'Close and lock the lid' for full details.
5. Press **Slow Cook**. The indicator light blinks.
6. The default or last-used cooking time displays. To change it, press **Time** and turn the **Control Dial** to change it, then press **Control Dial** to select it.
7. The default or last-used cooking temperature displays. To change it, press **Temp** and turn the **Control Dial** to change it, then press **Control Dial** to select it.
8. Keep Warm is **On** by default. If you want to turn it off, press **Keep Warm**.

9. Press **Start**. The Progress Bar shows **Preheating** and the Duo Crisp starts heating. The display shows **Preheating**.
10. When the pressure is ready, the Duo Crisp starts slow cooking. The unit displays **Cooking** and the cooking timer starts counting down.
11. When the timer reaches 00:00, cooking stops.
12. Press **Cancel** if you want to finish cooking before the timer stops.

Keep warm

When cooking completes and Keep Warm is turned on, the timer begins counting from **00:00** up to 10 hours (**10:00**). If Keep Warm is turned off, the display shows **End**.

SOUS VIDE

Sous Vide cooks food underwater in an air-tight, food-safe bag, for a long period of time. Food cooks in its own juices and comes out delicious and very tender. This program does not use pressure to cook food.

Choose from these settings to sous vide:

| Default Temp. | Min. Temp. | Max. Temp. | Default Cook Time | Min. Cook Time | Max. Cook Time |
|---------------|--------------|---------------|--------------------|--------------------|---------------------------------|
| 56°C 133°F | 25°C 77°F | 90°C 194°F | 3 hours (03:00) | 30 mins (00:30) | 99 hours, 30 mins (99:30) |

What you need to sous vide

- Tongs
- Food safe, airtight, re-sealable food pouches
OR
- Vacuum sealer and food-safe vacuum bags

How to sous vide

Prep

Cut, chop, season or marinate your ingredients according to your recipe.

Preheat

1. Place the Inner Cooking Pot into the cooker base.
2. Make sure the Pressure Cooking Inner Cover is installed in the Ultimate Lid.
3. Close the lid on the cooker base and lock it.
See 'Close and lock the lid' for full details.
4. Press **Sous Vide**. The indicator light blinks.
5. The default or last-used cooking time displays. To change it, press **Time** and turn the **Control Dial** to change it, then press **Control Dial** to select it.

6. The default or last-used cooking temperature displays. To change it, press **Temp** and turn the **Control Dial** to change it, then press **Control Dial** to select it.
7. Press **Start**. The Progress Bar shows **Preheating** and the Duo Crisp starts heating. The display shows **Preheating**.

Cook

1. When display shows **Add Food**, unlock and open the lid and add cooking pouch.
2. Reclose and lock the lid. The unit displays **Cooking**.
3. When timer ends, display shows **End**.
4. Press **Cancel** if you want to finish cooking before the timer stops.

Keep warm

When cooking completes and Keep Warm is turned on, the timer begins counting from 00:00 up to 10 hours (10:00). If Keep Warm is turned off, the display shows End. Keep warm not available for Sous Vide.

Remove food

When cooking completes, the display shows End. Use the tongs to carefully remove the cooking pouch.

YOGURT

You can use your Duo Crisp to easily make delicious, fermented dairy and non-dairy yogurt.

Choose from these settings for making yogurt:

| Pasteurizing Temperature | Fermenting Temperature | Pasteurizing Time | Default Fermenting Time | Min Fermenting Time | Max Fermenting Time |
|--------------------------|------------------------|--|-------------------------|---------------------|---------------------|
| Automatically set | Automatically set | Automatically set 30 minutes (00:30) | 8 hours (08:00) | 6 hours (06:00) | 24 hours (24:00) |

How to make yogurt

Making yogurt is a 3-step process, starting with pasteurizing the milk, then adding yogurt starter, and finally cooling the yogurt. Be sure to follow a trusted recipe.

Prep

1. Prepare the ingredients according to your recipe.
2. Place the ingredients into the Inner Cooking Pot.

Pasteurize

1. Place the Inner Cooking Pot into the cooker base.
2. Make sure the Pressure Cooking Cover is installed in the Ultimate Lid.
3. Close the lid on the cooker base and lock it.
4. See 'Close and lock the lid' for full details.
5. Press **Yogurt**. The indicator light blinks.
6. Press **Start**. The first Progress Bar displays under Cooking and the Duo Crisp starts heating. The display shows **Step 1. Pasteurize**.
7. When pasteurization is done, the Duo Crisp starts cooling down, and the second Progress Bar displays under Cooking. Open lid to cool down faster, takes approximately one and half hour. The display shows **Cooling Down**.

Ferment

1. When the Duo Crisp reaches the correct temperature for fermentation, the display shows **Add Yogurt Starter**. Add the yogurt starter and close lid.
2. You have 30 minutes to add the yogurt starter. If you do nothing, the Yogurt program will automatically stop.
3. The default or last-used fermenting time displays. To change it, press Time and turn the Control Dial to change it, then press Time again to select it.
4. Press Start. The third Progress Bar displays under Cooking. The display shows **Step 2. Ferment**.
5. When the fermenting step is finished, the display shows **End**.
6. Press Cancel if you want to finish cooking before the timer stops.

Cool

1. Allow yogurt to cool.
2. Place in refrigerator for 12-24 hours to develop flavors.

How much to make?

| Instant Pot Size | Minimum Milk Volume | Maximum Milk Volume |
|-------------------------|-----------------------------|------------------------------|
| 6.5 Quarts / 6.2 Liters | 4 Cups (32 oz / 1000 mL) | 4 Quarts (128 oz / 3.8 L) |

AIR FRY

You can air fry all sorts of foods, fresh or frozen, for a crisp finish without all the oil.

Choose from these settings for air frying:

| Default Temp | Min. Temp | Max. Temp | Default Cook Time | Min. Cook Time | Max. Cook Time |
|----------------|---------------|----------------|-----------------------|---------------------|-------------------|
| 204°C 400°F | 82°C 180°F | 204°C 400°F | 18 minutes (00:18) | 1 minute (00:01) | 1 hour (01:00) |

How to air fry

Prep

Prepare the ingredients according to your recipe and have them ready.

Preheat

1. Place the Inner Cooking Pot into the cooker base.
2. Place the Air Fry/Cooking Rack inside the Inner Cooking Pot.
3. Make sure the Pressure Cooking Inner Cover is NOT installed in the Ultimate Lid.
4. Close the lid on the cooker base.
See 'How to lock the lid' for full details.
5. Press **Air Fry**. The indicator light blinks.
6. The default or last-used cooking time displays. To change it, press **Time** and turn the **Control Dial** to change it, then press **Control Dial** to select it.
7. The default or last-used cooking temperature displays. To change it, press **Temp** and turn the **Control Dial** to change it, then press **Control Dial** to select it.
8. When the unit displays **Add Food**, open the lid, add the prepared food, and close the lid.

9. The Duo Crisp starts air frying, and the unit displays **Cooking**.
10. When the unit displays **Turn Food**, open the lid, turn the food, and close the lid.
11. When the timer reaches 00:00, cooking stops.
12. Press **Cancel** if you want to finish cooking before the timer stops.

BAKE + ROAST

You can bake foods like breads, cakes and pastries, or roast meats and vegetables.

Choose from these settings for each smart program:

| Smart Program | Default Temp. | Min. Temp. | Max. Temp. | Default Cook Time | Min. Cook Time | Max. Cook Time |
|---------------|----------------|---------------|----------------|--------------------|------------------|-------------------|
| Bake | 193°C 365°F | 82°C 180°F | 204°C 400°F | 30 mins (00:30) | 1 min (00:01) | 1 hour (01:00) |
| Roast | 204°C 380°F | 82°C 180°F | 204°C 400°F | 40 mins (00:40) | 1 min (00:01) | 1 hour (01:00) |

How to bake or roast

Prep

1. Prepare the ingredients according to your recipe.
2. If baking, place the ingredients into an oven-safe baking dish that fits in the Duo Crisp cooker base.

Leave approximately 1 in / 2.5 cm of space around all sides of the baking dish to allow heat to circulate evenly.

3. If roasting, place the ingredients into the Air Fry/Cooking Rack.

Cook

1. Place the Inner Cooking Pot into the cooker base, and then place the Air Fry/Cooking Rack inside the Inner Cooking Pot.
2. Make sure the Pressure Cooking Inner Cover is NOT installed in the Ultimate Lid.
3. Close the lid on the cooker base.
See 'How to lock the lid' for full details.
4. Press **Bake** or **Roast**. The indicator light blinks.
5. The default or last-used cooking time displays. To change it, press **Time** and turn the **Control Dial** to change it, then press **Control Dial** to select it.

6. The default or last-used cooking temperature displays. To change it, press **Temp** and turn the **Control Dial** to change it, then press **Control Dial** to select it.
7. Press **Start**. The Progress Bar shows **Preheating** and the Duo Crisp starts heating. The display shows **Preheating**.
8. When the unit displays **Add Food**, open the lid, place Air Fry/ Cooking Rack inside the Inner Cooking Pot, and close the lid.
9. The Duo Crisp starts baking/roasting, and the unit displays **Cooking** and the cooking timer starts counting down.
10. When the timer reaches 00:00, cooking stops.
11. Press **Cancel** if you want to finish cooking before the timer stops.

BROIL

You can broil foods like meats, seafood and vegetables.

Choose from these settings for broiling:

| Default Temp. | Min. Temp. | Max. Temp. | Default Cook Time | Min. Cook Time | Max. Cook Time |
|----------------|----------------|----------------|----------------------|------------------|--------------------|
| 204°C 400°F | Not adjustable | Not adjustable | 6 minutes (00:06) | 1 min (00:01) | 40 mins (00:40) |

How to broil

Prep

1. Prepare the ingredients according to your recipe.
2. Place the ingredients into the Air Fry/Cooking Rack.

Cook

1. Place the Inner Cooking Pot into the cooker base.
2. Place the Air Fry/Cooking Rack inside the Inner Cooking Pot.
3. Make sure the Pressure Cooking Inner Cover is NOT installed in the Ultimate Lid.
4. Close the lid on the cooker base.
See 'How to lock the lid' for full details.
5. Press **Broil**. The indicator light blinks.
6. The default or last-used cooking time displays. To change it, press **Time** and turn the **Control Dial** to change it, then press **Control Dial** to select it.
7. Press **Start**. The Duo Crisp starts broiling, and the unit displays **Cooking** and the cooking timer starts counting down.
8. When the timer reaches 00:00, cooking stops.
9. Press **Cancel** if you want to finish cooking before the timer stops.

DEHYDRATE + PROOFING

You can dehydrate foods like fruit and vegetables or proof dough before baking.

Choose from these settings for each smart program:

| Smart Program | Default Temp. | Min. Temp. | Max. Temp. | Default Cook Time | Min. Cook Time | Max. Cook Time |
|---------------|---------------|---------------|---------------|--------------------|--------------------|---------------------|
| Dehydrate | 51°C 125°F | 40°C 105°F | 73°C 165°F | 7 hours (07:00) | 1 hour (01:00) | 72 hours (72:00) |
| Proof | 25°C 77°F | 23°C 75°F | 35°C 95°F | 1 hour (01:00) | 30 mins (00:30) | 3 hours (03:00) |

How to dehydrate or proof

Prep

1. Prepare the ingredients according to your recipe.
2. Place the ingredients into the Air Fry/Cooking Rack.

Cook

1. Place the Inner Cooking Pot into the cooker base.
2. Place the Air Fry/Cooking Rack inside the Inner Cooking Pot.
3. Make sure the Pressure Cooking Inner Cover is NOT installed in the Ultimate Lid.
4. Close the lid on the cooker base.
See 'How to lock the lid' for full details.
5. Press **Dehydrate** or **Proof**. The indicator light blinks.
6. The default or last-used cooking time displays. To change it, press **Time** and turn the **Control Dial** to change it, then press **Control Dial** to select it.
7. The default or last-used cooking temperature displays. To change it, press **Temp** and turn the **Control Dial** to change it, then press **Control Dial** to select it.

8. Press **Start**. The Duo Crisp starts dehydrating/proofing, and the unit displays **Cooking** and the cooking timer starts counting down.
9. When the timer reaches 00:00, cooking stops.
10. Press **Cancel** if you want to finish cooking before the timer stops.

KEEP WARM

You can choose to turn Keep Warm on automatically after cooking on many smart programs. You can also use Keep Warm to reheat food.

Choose from these settings in the Keep Warm smart program:

| Default Temp | Min. Temp | Max. Temp | Default Cook Time | Min. Cook Time | Max. Cook Time |
|--------------|--------------------------|---------------------------|---------------------|--------------------|---------------------|
| None | Low (62°C / 144°F) | High (77°C / 171°F) | 10 hours (10:00) | 10 mins (00:10) | 10 hours (10:00) |

How to reheat

Prep

Place the food to be reheated into the Inner Cooking Pot.

Preheat

1. Place the Inner Cooking Pot into the cooker base.
2. Please make sure to install the pressure cooking cover on the ultimate lid then close and lock the lid.
See 'How to lock the lid' for full details.
3. Choose **Keep Warm** on the **Control Panel**. The default or previous time and temperature settings display.
4. To change the reheating time, press **Time**, then turn the **Control Dial** to select a new reheating time.
5. To change the cooking temperature, press **Temperature**, then turn the **Control Dial** to select a new cooking temperature.
6. Press **Start**. The Progress Bar shows **Keep Warm** and the timer starts counting down.
7. When reheating completes, the display shows **End**.

CLEANING

Clean your Instant Duo Crisp after each use. Always unplug the unit and let all parts cool to room temperature before cleaning. Before use or storing, make sure all surfaces are dry.

⚠ WARNING

DO NOT immerse power cord, plug or the appliance in water or other liquid, which may result in electric shock.

| Part | Cleaning instructions |
|---|--|
| Accessories <ul style="list-style-type: none">• Air Fry/ Cooking Rack• Pressure Cooking Cover• Condensation Collector | <ul style="list-style-type: none">• Wash after each use• Hand wash with hot water and mild dish soap or wash in dishwasher, top rack• Never use harsh chemical detergents, powders or scouring pads on accessories• Empty and rinse condensation collector after each use |
| Ultimate Lid | <ul style="list-style-type: none">• Use a barely-damp cloth to wipe any particles |
| Inner Cooking Pot | <ul style="list-style-type: none">• Wash after each use.• Hand wash with hot water and mild dish soap or wash in dishwasher*• Hard water stains may need a vinegar-dampened sponge and scrubbing to remove• For tough or burned food residue, soak in hot water for a few hours before cleaning• Dry all exterior surfaces before placing in cooker base |
| Power cord | <ul style="list-style-type: none">• Use a barely-damp cloth to wipe any particles off cord |
| Cooker base | <ul style="list-style-type: none">• Wipe the inside of the cooker base as well as the condensation rim with a barely-damp cloth, and allow to air dry• Clean the outside of the cooker base and the control panel with a soft, barely-damp cloth or sponge |

**Some discoloration may occur after machine washing, but this will not affect the cooker's safety or performance.*

TROUBLE SHOOTING

| Problem | Cause | Solution |
|---|---|--|
| Display remains blank after connecting the power cord | Bad power connection or no power | Inspect power cord for damage. If damage is noticed, contact Consumer Care. Check outlet to ensure it is powered. |
| | Cooker's electrical fuse has blown | Contact Consumer Care. |
| Steam leaks from side of lid | Lid not closed properly | Open, then close lid. |
| | Inner cooking pot rim may be misshapen | Check for deformation and contact Consumer Care. |
| Difficulty closing lid | Contents in cooker are still hot | Press Steam Release on the Control Panel, then lower lid onto cooker base and wait for steam and temperature to reduce before attempting to close the lid. |
| Difficulty opening lid | Pressure inside the cooker | Release pressure according to recipe; only open lid after the display shows "OK to open lid". |
| Inner pot is stuck to lid when cooker is open | Cooling of inner pot may create suction, causing inner pot to adhere to the lid | To release the vacuum, press Steam Release on the Control Panel and wait for food content inside inner pot to cool down. |
| | Too little liquid in the inner pot | Check for scorching on bottom of inner pot. Add thin, water-based liquid to the inner pot: 1 1/2 cups (12 oz / 375 mL) |

| Problem | Cause | Solution |
|--|--|---|
| Minor steam leaking/ hissing from steam release valve during cook cycle | Lid not set to Lock position | Check Lid Lock to ensure it's set to Lock. |
| | Cooker is regulating excess pressure | This is normal; no action required. |
| Steam gushes from steam release valve when quick release button is in Seal position | Not enough liquid in the inner pot | Add thin, water-based liquid to the inner pot: 1 1/2 cups (12 oz / 375 mL) |
| | Pressure sensor control failure | Contact Consumer Care. |
| Occasional clicking or light cracking sound | The sound of power switching and expanding pressure board when changing temperatures | This is normal; no action needed. |
| | Bottom of the cooking pot is wet | Wipe exterior surfaces of inner pot. Ensure heating element is dry before inserting inner pot into cooker base. |

ERROR CODES

If the control panel displays an error code from this list, there is an issue with the Duo Crisp with Ultimate Lid. Here are the actions you should take to fix the problem.

| Code | Cause | Solution |
|-----------|---|---|
| C1, C3 | Faulty sensor | Contact Consumer Care. |
| C4 | Faulty control panel connection | Contact Consumer Care. |
| C6 | Fault pressure switch | Contact Consumer Care. |
| C7 | Loss of pressure | Cancel cooking, turn the cooker off, then turn the cooker back on to try to reset. If this doesn't solve the problem, contact Consumer Care. |
| Food burn | High temperature detected at bottom of inner pot; cooker stops to avoid overheating | Turn the cooker off, release pressure according to the recipe, and check the bottom of the cooking pot for food deposits; clear the deposits if possible and restart cooking. |
| PrSE | Pressure has accumulated during a non-pressure cooking program | Cancel cooking and set Steam Release to Vent. Once steam is released, restart cooking. |

LEARN MORE

There's a whole world of Instant Duo Crips with Ultimate Lid information and help just waiting for you. Here are some of the most helpful resources.

Register your product

[Instanthome.com/register](https://instanthome.com/register)

Contact Consumer Care

In the Instant Brand Connect app
[Instanthome.com/customer-care-center](https://instanthome.com/customer-care-center)
support@instanthome.com

Instant Brands Connect App with 1000+ recipes

[Instanthome.com](https://instanthome.com)
iOS and Android app stores

Cooking charts and more recipes

[Instanthome.com](https://instanthome.com)

How-to videos, tips and more

[Instanthome.com](https://instanthome.com)

Replacement parts and accessories

[Instanthome.com](https://instanthome.com)

Join the community



Product specifications

| Model | Volume | Wattage | Power | Weight | Dimensions |
|-----------|----------------------------|---------------|----------------|------------------------|--|
| SLC065000 | 6.5 Quarts / 6.2 Litres | 1500 watts | 120V ~ 60Hz | 10.6 kg / 23.32 lbs | in: 15.5 x 15.4 x 13.4 cm: 39.4 x 39.2 x 34 |

WARRANTY

One (1) Year Limited Warranty

This One (1) Year Limited Warranty applies to purchases made from authorized retailers of Instant Brands LLC ("Instant Brands") by the original appliance owner and is not transferable. Proof of original purchase date and, if requested by Instant Brands, return of your appliance, is required to obtain service under this Limited Warranty. Provided the appliance was used in accordance with the use & care instructions, Instant Brands will, in its sole and exclusive discretion, either: (i) repair defects in materials or workmanship; or (ii) replace the appliance. In the event that your appliance is replaced, the Limited Warranty on the replacement appliance will expire twelve (12) months from the date of receipt. Failure to register your product will not reduce your warranty rights. The liability of Instant Brands, if any, for any allegedly defective appliance or part will not exceed the purchase price of a comparable replacement appliance.

What is not covered by this warranty?

- Products purchased, used, or operated outside of the United States and Canada.
- Products that have been modified or attempted to be modified.
- Damage resulting from accident, alteration, misuse, abuse, neglect, unreasonable use, use contrary to the operating instructions, normal wear and tear, commercial use, improper assembly, disassembly, failure to provide reasonable and necessary maintenance, fire, flood, acts of God, or repair by anyone unless directed by an Instant Brands representative.
- Use of unauthorized parts and accessories.
- Incidental and consequential damages.
- The cost of repair or replacement under these excluded circumstances.

EXCEPT AS EXPRESSLY PROVIDED HEREIN AND TO THE EXTENT PERMITTED BY APPLICABLE LAW, INSTANT BRANDS MAKES NO WARRANTIES, CONDITIONS OR REPRESENTATIONS, EXPRESS OR IMPLIED, BY STATUTE, USAGE, CUSTOM OF TRADE OR OTHERWISE WITH RESPECT TO THE APPLIANCES OR PARTS COVERED BY THIS WARRANTY, INCLUDING BUT NOT LIMITED TO, WARRANTIES, CONDITIONS, OR REPRESENTATIONS OF WORKMANSHIP, MERCHANTABILITY, MERCHANTABLE QUALITY, FITNESS FOR A PARTICULAR PURPOSE OR DURABILITY.

Some states or provinces do not allow for: (1) the exclusion of implied warranties of merchantability or fitness; (2) limitations on how long an implied warranty lasts; and/or (3) the exclusion or limitation of incidental or consequential damages; so these limitations may not apply to you. In these states and provinces, you have only the implied warranties that are expressly required to be provided in accordance with applicable law. The limitations of warranties, liability, and remedies apply to the maximum extent permitted by law. This limited warranty gives you specific legal rights, and you may also have other rights which vary from state to state or province to province.

Product Registration

Please visit www.instanthome.com/register to register your new Instant Brands appliance. Failure to register your product will not diminish your warranty rights. You will be asked to provide the store name, date of purchase, model number (found on the back of your appliance) and serial number (found on the bottom of your appliance) along with your name and email address. The registration will enable us to keep you up to date with product developments, recipes and contact you in the unlikely event of a product safety notification. By registering, you acknowledge that you have read and understand the instructions for use, and warnings set forth in the accompanying instructions.

Warranty Service

To obtain warranty service, please contact our Consumer Care Department by email to support@instanthome.com. You can also create a support ticket online at www.instanthome.com. If we are unable to resolve the problem, you may be asked to send your appliance to the Service Department for quality inspection. Instant Brands is not responsible for shipping costs related to warranty service. When returning your appliance, please include your name, mailing address, email address, phone number, and proof of the original purchase date as well as a description of the problem you are encountering with the appliance.

Distributed by Instant Brands LLC
3025 Highland Parkway, Suite 700
Downers Grove, IL 60515 U.S.

instanthome.com

© 2022 Instant Brands LLC
140-0068-01-0102

INSTANT and INSTANT POT
are registered trademarks of
Instant Brands Holdings Inc.